

DIGITAL SERVO DRIVE FOR BRUSH & BRUSHLESS MOTORS

[AFS] Advanced Feature Set

- 32-bit Floating Point Filters
- Multiple Advanced Filters
- Frequency Analysis Tools

Control Modes

- Cyclic Synchronous Position-Velocity-Torque (CSP, CSV, CST)
- Cyclic Synchronous Torque with Commutation Angle (CSTCA)
- Profile Position-Velocity-Torque
- Interpolated Position, Homing
- Indexer, Point-to-Point, PVT
- Camming, Gearing

Command Interface

- CANopen® application protocol over EtherCAT (CoE)
- ASCII, Serial Binary, and Discrete I/O
- Stepper or Quad A/B Position Commands
- PWM Velocity-Torque Command
- Master encoder (Gearing, Camming)
- ±10 V Position-Velocity-Torque

Communications

- EtherCAT®
- RS-232

Feedback

- Primary Absolute
BiSS-C Unidirectional
SSI Absolute or Incremental
- Secondary Incremental
Differential Quad A/B/X
- Dual Feedback
- Digital Halls

I/O

- 1 Analog Input ±10V, 12-bit
- 5 High-speed Digital Inputs
- 1 Motor Overtemp Input
- 4 High-speed Digital Outputs

Safe Torque Off

- SIL 3, Category 3, PL e

Dimensions, Weight

- NES: 35 x 30 x 23.4 mm [1.38 x 1.18 x 0.92 in], 29 g [1.0 oz]
 - NES-Z: 35 x 47 x 33.6 mm [1.38 x 1.85 x 1.32], 57 g [2.0 oz]
 - NES-D: 97.1 x 112.4 x 45 mm [3.82 x 4.42 x 1.77 in], 221 g [7.8 oz]*
- *Note: Optional heatsink weight: 16.5 g [0.58 oz]

MODEL	Ic	Ip	Vdc
NES-090-10	5	10	9~90
NES-090-70	35	70	9~90
NES-180-10	5	10	20~180
NES-180-30	15	30	20~180

-Z and -D have these ratings.

Note: Append -D for Module/Dev Board Assy [-D]
Append -Z for Module/OEM Board Assy [-Z]

DESCRIPTION

Nano is the smallest servo drive that Copley offers and can be mounted directly on the motor or within robotic joints. It can satisfy requirements of the robotics, AGV, industrial machinery, medical/life-sciences and aerospace industries.

The NES module may be implemented in a customer application using only connectors, or it can be used when the power pins may be soldered for high load current applications. The NES-Z is a small form factor available for immediate integration into a customer application used with industry standard connectors.

NES

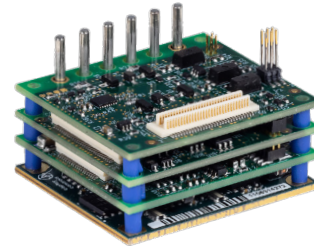

NES-Z

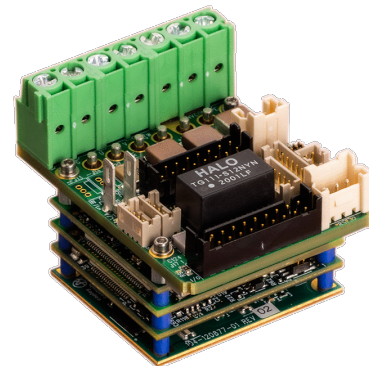

NES-D

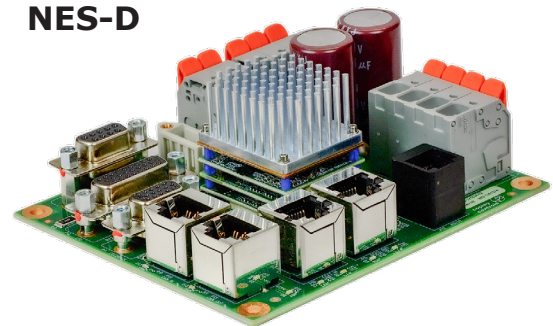

Note:

For NES-090-70-D and NES-090-180-30-D assemblies, heatsinks are installed at the factory.

For NES-090-10-D and NES-180-10-D assemblies, heatsinks are not installed at the factory.

DIGITAL SERVO DRIVE FOR BRUSH & BRUSHLESS MOTORS

GENERAL SPECIFICATIONS

Test conditions: Load = Wye connected load: 1 mH + 1Ω line-line. Ambient temperature = 25 °C. +HV = HVmax

MODEL	NES-090-10	NES-090-70	NES-180-10	NES-180-30	
	NES-090-10-D	NES-090-70-D	NES-180-10-D	NES-180-30-D	
	NES-090-10-Z	NES-090-70-Z	NES-180-10-Z	NES-180-30-Z	

OUTPUT POWER...	NES-090-10	NES-090-70	NES-180-10	NES-180-30	
Peak Current	10 (7.07)	* 70 (49.5)	10 (7.07)	30 (21.2)	ADC (ARMS, sinusoidal)
Peak Time	1	1	1	1	Sec
Continuous Current	5 (3.54)	* 35 (24.8)	5 (3.54)	15 (10.6)	ADC (ARMS, sinusoidal)
Peak Output Power	0.9	6.3	1.8	5.4	kW
Continuous Output Power	0.45	3.15	0.9	1.8	kW

* NES-090-70 must be soldered to a mounting PCBA to meet this output.

INPUT POWER	NES-090-10	NES-090-70	NES-180-10	NES-180-30	
HVmin to HVmax	+9 to +90	+9 to +90	+20 to +180	+20 to +180	Vdc, transformer-isolated
Ipeak	10	70	10	30	ADC (1 sec) peak
Icont	5	35	5	15	ADC continuous
VLOGIC	+9 to +60	+9 to +60	+9 to +60	+9 to +60	Vdc, transformer-isolated
VLOGIC Power	3 W with no encoder, 6 W with encoder +5V @ 500 mA, VLOGIC @ 24 Vdc				

PWM OUTPUTS	
Type	MOSFET 3-phase inverter, 16 kHz center-weighted PWM carrier, space-vector modulation
PWM Ripple Frequency	32 kHz

BANDWIDTH	
Current loop, small signal	2.5 kHz typical, bandwidth will vary with tuning & load inductance.
HV Compensation	Changes in HV do not affect bandwidth.
Current loop update rate	16 kHz (62.5 μs)
Position & Velocity loop update rate	4 kHz (250 μs)

COMMAND INPUTS	
EtherCAT	CANopen application protocol over EtherCAT (CoE): Cyclic Synchronous Position/Velocity/Torque Profile Position/Velocity/Torque, Interpolated Position (PVT), Homing Cyclic Synchronous Torque with Commutation Angle (CSTCA)
Signals	RX1+, RX1-, TX1+, TX1-, RX2+, RX2-, TX2+, TX2-
Stand-alone Mode	
Digital Position reference	Pulse/Direction, CW/CCW Stepper commands (2 MHz maximum rate) Quad A/B Encoder 2 M line/sec, 8 Mcount/sec (after quadrature)
Digital Torque & Velocity reference	PWM, Polarity PWM = 0% - 100%, Polarity = 1/0 PWM 50% PWM = 50% ±50%, no polarity signal required PWM frequency range 1 kHz minimum, 100 kHz maximum PWM minimum pulse width 220 ns
Indexing	Up to 32 sequences can be launched from inputs or ASCII commands.
Camming	Up to 10 CAM tables can be stored in flash memory.
ASCII	RS-232, 9600~230,400 Baud, 3-wire

DIGITAL INPUTS MODULE	
Number	6
IN1~5	General purpose inputs LV CMOS 3.3V Schmitt trigger, 100 ns RC filter, max. input voltage = +12 Vdc, 10 kΩ pull-up to +5 Vdc 2.2 Vdc min. positive threshold, 0.6 Vdc max. negative threshold RC time-constant assumes active drive on inputs and does not include 10 kΩ pull-ups
IN6	Motor overtemperature, LV CMOS 3.3V Schmitt trigger, 33 μS RC filter, max. input voltage = +12 Vdc 4.99 kΩ pull-up to +5 Vdc, 2.2 Vdc min. positive threshold, 0.6 Vdc max. negative threshold

DIGITAL INPUTS NES-D, NES-Z	
IN1~3	24 V tolerant, HC CMOS 5.0V Schmitt trigger, 330 μs RC filter, 0~24 Vdc compatible, 10 kΩ pull-up to +5 Vdc 2.2 Vdc min. positive threshold, +0.6 Vdc max. negative threshold
IN4~5	LV CMOS 3.3V Schmitt trigger, 100 ns RC filter, max. input voltage = +12 Vdc, 10 kΩ pull-up to +5 Vdc 2.2 Vdc min. positive threshold, 0.6 Vdc max. negative threshold
IN6	Motor over-temperature, HC CMOS 5.0V Schmitt trigger, 330 μS RC filter, max. input voltage = +12 Vdc 1.6 kΩ pull-up to +5 Vdc, 2.2 Vdc min. positive threshold, 0.6 Vdc max. negative threshold

DIGITAL OUTPUTS MODULE	
Number	4
OUT1~4	74HCT14 5 V CMOS Schmitt trigger, functions programmable, +5 Vcc Source -4 mA @ VOH = 4.18 Vdc, Sink 4 mA @ VOL = 0.26 Vdc

DIGITAL OUTPUTS NES-D, NES-Z	
Number	4
OUT1~3	74HCT14 5 V CMOS Schmitt trigger, functions programmable, +5 Vcc Source -4 mA @ VOH = 4.18 Vdc, Sink 4 mA @ VOL = 0.26 Vdc
OUT4 (NES-D)	Brake control, programmable release time followed by programmable PWM duty-cycle for holding current.

DIGITAL SERVO DRIVE FOR BRUSH & BRUSHLESS MOTORS

ANALOG INPUT

Number	1
Type	Differential, ± 10 Vdc range, 5.0 k Ω input impedance to a 12 bit ADC, single-pole low pass filter with a 14.5 kHz -3dB bandwidth
Function	Torque, Velocity, or Position command. Or, as a general purpose analog input

SERIAL COMMUNICATION PORT

Signals	RxD, TxD, SGND RxD input is 74LVC14 3.3 V Schmitt trigger with 10 k Ω pull-up to +5V TxD output is 74HCT14 5 V Schmitt trigger
Mode	Full-duplex, DTE serial communication port for drive setup and control, 9,600 to 230,400 bits/second
Protocol	ASCII or Binary format
Isolation	Non-isolated. Referenced to Signal Ground

SERIAL COMMUNICATION PORT, NES-D, NES-Z

An ADM3101E transceiver provides standard RS-232 signal levels. An RJ11 connector accepts commonly used cable connectors.	
Signals	RxD, TxD, SGND

ETHERCAT PORT

Format	100BASE-TX
Protocol	EtherCAT, CANopen Application Protocol over EtherCAT (CoE)
Isolation	External magnetics required for module. NES-D and NES-Z have internal magnetics. Max. voltage with respect to grounds: 32 Vdc

MOTOR CONNECTIONS

Motor U,V,W	Drive outputs to 3-phase brushless motor, Wye or delta connected, for DC brush motor use outputs U & V Minimum inductance: 200 μ H line-line
Encoder	Digital encoders, incremental and absolute (see FEEDBACK below)
Halls	Digital U/V/W
Motemp	Input is programmable to disable the drive if motor sensor drives input HI or LO.

FEEDBACK

<i>Incremental encoders:</i>	
Digital Incremental Encoder	Quadrature signals, (A, /A, B, /B, X, /X), differential (X, /X Index signals not required). RS-422 line receivers, 5 MHz maximum line frequency (20 M counts/sec), 74HCT thresholds
<i>Absolute encoders:</i>	
BiSS-C Unidirectional, SSI	MA+, MA- (X, /X), SL+, SL- (A, /A) signals, clock output from drive, data returned from encoder
<i>Terminators</i>	All encoder data inputs and clock outputs are differential and require external terminators.
<i>Commutation:</i>	Hall signals (U,V,W), 15 k Ω pull-up to +5V, 15 k Ω /100 pF RC to 74LVC3G14 Schmitt trigger at +5 Vcc

HALLS

U, V, W:	Single-ended, 120° electrical phase difference Schmitt trigger, 1.0 μ s RC filter from active HI/LO sources, 5 Vdc compatible 15 k Ω pull-up to +5 Vdc, 74LVC, 3.3 V thresholds
----------	--

+5V OUTPUT

Number	1
Rating	150 mA maximum. Protected for overload or shorts. Available for optional peripherals immediately adjacent to the module.

+3.3V OUTPUT

Number	3
Rating	150 mA maximum. Protected for overload or shorts. Available for optional microcontroller, RS-232 Transceiver, CANopen Transceiver, LEDs, and Address Switches.

+5VENC OUTPUT

Number	2
Rating	250 mA nominal, 500 mA maximum. Protected for overload and shorts. Note that the maximum total current for both outputs combined is 500 mA.

DIGITAL SERVO DRIVE FOR BRUSH & BRUSHLESS MOTORS

SAFE TORQUE OFF (STO)

Function	PWM outputs are inactive and the current to the motor will not be possible when the STO function is active.
Safety Integrity Level	SIL 3, Category 3, Performance Level e (PL e)
Inputs	2 two-terminal: STO-IN1, STO-COM1, STO-IN2, STO-COM2
Type	Opto-isolators, 5V compatible
Disabling	Connecting both STO inputs to +5V will deactivate the STO function.

PROTECTIONS

HV Overvoltage	+HV > +95 ±1 Vdc Drive outputs turn off until +HV is < +95 ±1 Vdc (90 V model). +HV > +185 ±1 Vdc Drive outputs turn off until +HV is < +185 ±1 Vdc (180 V models).
HV Undervoltage	+HV < +9.0 ±0.5 Vdc Drive outputs turn off until +HV > +9.0 Vdc ±0.5 Vdc (90 V models). +HV < +20.0 ±0.5 Vdc Drive outputs turn off until +HV > +20.0 Vdc ±0.5 Vdc (180 V models).
Drive Over-Temperature	PC Board > 90 °C +3/-0 °C Programmable as latching or temporary fault
Short Circuits	Output to output, output to ground, internal PWM bridge faults
I ^T Current Limiting	Programmable: continuous current, peak current, peak time for drive and motor
Latching / Non-Latching	Programmable response to errors

MECHANICAL & ENVIRONMENTAL

Size, Weight	NES: 35 x 30 x 21.6 mm [1.38 x 1.18 x 0.85 in], 1.0 oz [29 g] NES-Z: 54.62 x 35 mm [2.25 x 1.378 in], 2.0 oz [57 g] NES-D: 112.4 X 97.2 X 36.86 mm [4.42 X 3.82 X 1.45 in], 7.8 oz [221 g]* *The asterisk indicates to add 0.58 oz [.0165 kg] for optional heatsink. Note: For NES-090-70-D and NES-180-30-D assemblies, the heatsinks are installed at the factory. For NES-090-10, NES-090-10-D, NES-180-10 and NES-180-10-D assemblies, the heatsinks are optional.
Ambient Temperature	0 to +45 °C operating, -40 to +85 °C storage
Humidity	0 to 95%, non-condensing
Altitude	≤ 2000 m (6,562 ft)
Vibration	2 g peak, 10~500 Hz (Sine)
Shock	10 g, 10 ms, ½ Sine pulse
Contaminants	Pollution Degree 2

AGENCY STANDARDS CONFORMANCE

Standards and Directives

Functional Safety

- IEC 61508-1, IEC 61508-2, IEC 61508-3, (SIL 3)
- Directive 2006/42/EC (Machinery)
- ISO 13849-1 (Cat 3, PL e)
- IEC 61800-5-2 (SIL 3)

Product Safety

- Directive 2014/35/EU (Low Voltage)
- IEC 61800-5-1

EMC

- Directive 2014/30/EU (EMC)
- IEC 61800-3
- IEC 61800-5-2

Restriction of the Use of Certain Hazardous Substances (RoHS)

- Directive 2011/65/EU and its amendments 2015/863/EU

Approvals

UL recognized component to:

- UL 61800-5-1, UL 61800-5-2
- IEC 61800-5-1, IEC 61800-5-2

FUNCTIONAL SAFETY



ISO 13849-1
Up to PL e (Cat.3)
IEC 61800-5-2
Up to SIL 3

 DANGER	Refer to the Copley User Guide for the NANO Family, Part Number 16-121699.
	The information provided in the Copley User Guide for NANO Family, Part Number 16-121699 must be considered for any application using the NANO drive STO feature. Failure to heed this warning can cause equipment damage, injury, or death.

ETHERCAT COMMUNICATIONS

EtherCAT is the open, real-time Ethernet network developed by Beckhoff based on the widely used 100BASE-TX cabling system. EtherCAT enables high-speed control of multiple axes while maintaining tight synchronization of clocks in the nodes. Data protocol is CANopen application protocol over EtherCAT (CoE) based on CiA 402 for motion control devices. More information on EtherCAT can be found on this web-site: <http://ethercat.org>

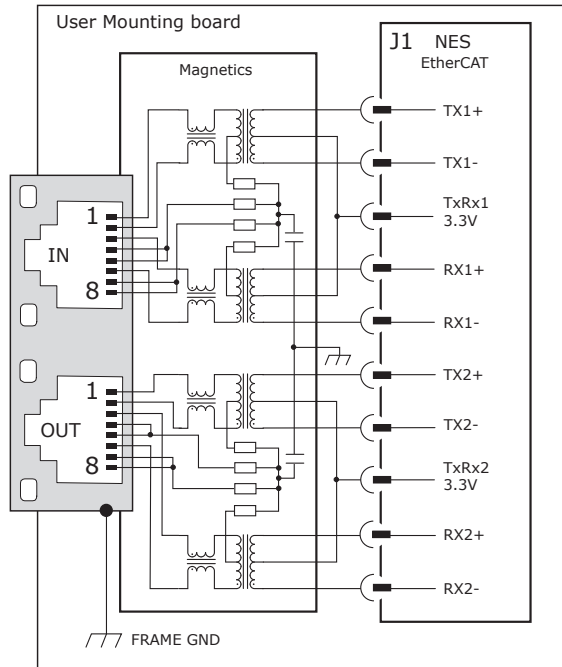

Network RJ-45

IN Name	Pin	OUT Name
Ecat TX1+	1	Ecat TX2+
Ecat TX1-	2	Ecat TX2-
Ecat RX1+	3	Ecat RX2+
R/C	4	R/C
	5	
Ecat RX1-	6	Ecat RX2-
R/C	7	R/C
	8	

Note: The term, R/C, refers to the 75 Ω and 1000 pF components shown.

Drive J1

Name	Pin
[TX1+] TXPA	24
[TX1-] TXNA	26
+3.3V_TXRX1	19
[RX1+] RXPA	20
[RX1-] RXNA	22
[Tx2+] TXPB	25
[Tx2-] TXNB	23
+3.3V_TXRX2	21
[Rx2+] RXPB	29
[Rx2-] RXNB	27

RS-232 COMMUNICATIONS

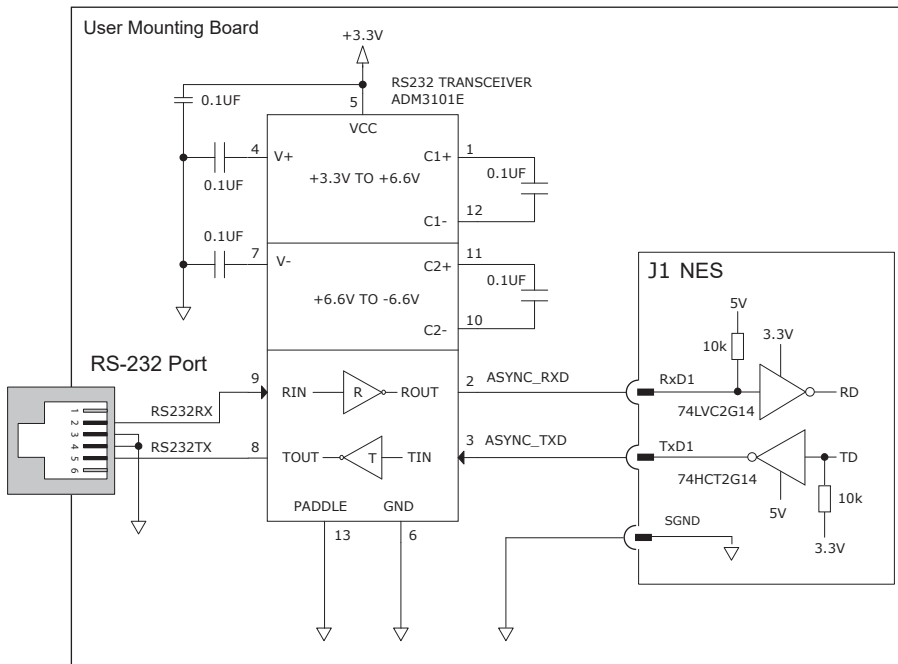

The serial port is a full-duplex, three-wire (RxD, TxD, SGND) type that operates from 9,600 to 230,400 Baud. Using the CME software, it can be programmed for drive configuration and setup or programmed for the external equipment sending the ASCII commands.

In the diagram, the circuit shown is used on the -D and -Z boards. It is recommended for user's PC boards. It converts the single-ended TTL signals levels in the NES into the ANSI RS-232 levels which are the standard for serial communications and computer COMM ports.

RS-232 Port

Name	Pins
RS232RX	2
RS232TX	5
SGND	3,4

Drive J1

Name	Pins
RxD1	30
TxD1	32
SGND	34

SAFE TORQUE OFF (STO)

The Safe Torque Off (STO) function is defined in IEC 61800-5-2. Two channels are provided which, when de-energized, prevent the upper and lower devices in the PWM outputs from producing torque in the motor.

This provides a positive OFF capability that cannot be overridden by the control firmware, or associated hardware components. When the opto-couplers are energized (current is flowing in the input diodes), the control core will be able to control the On/Off state of the PWM outputs to produce torque in the motor.

INSTALLATION

 DANGER	Refer to the Copley User Guide for the NANO Family, Part Number 16-121699.
	The information provided in the Copley User Guide for NANO Family, PN:16-121699, must be considered for any application using the drive's STO feature. FAILURE TO HEED THIS WARNING CAN CAUSE EQUIPMENT DAMAGE, INJURY, OR DEATH.

STO DISABLE

In order for the PWM outputs of the NES to be activated, the current must be flowing through the opto-couplers that are connected to the STO-IN1 and STO-IN2 terminals and the drive must be in an ENABLED state. When either of the opto-couplers are OFF, the drive is in a Safe Torque Off (STO) state and the PWM outputs cannot be activated by the control core to drive a motor.

In the diagram, it shows the connections that will energize both opto-couplers from a +5V source. When this is done, the STO feature is disabled and control of the output PWM stage is under control of the digital control core. **If the STO feature is not used, these connections must be made in order for the drive to be enabled.**

STO DISABLE CONNECTIONS

FUNCTIONAL DIAGRAM



Note: The current must flow through both of the opto-couplers before the drive can be enabled.

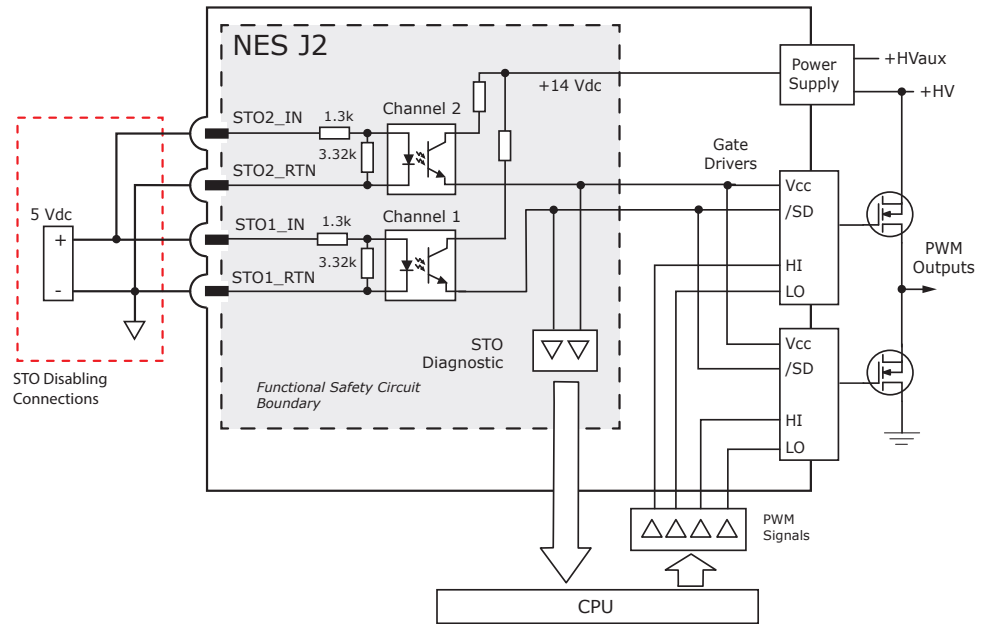

J2 STO

Name	Pin	Name	
STO_STATUS_OUTPUT	6	5	STO_STATUS_OUTPUT_RTIN
STO2_IN	4	3	STO2_RTIN
STO1_IN	2	1	STO1_RTIN



ALL PIN NUMBERING INFORMATION FOR MODULE-LEVEL STO CONNECTIONS IN THIS DOCUMENT IS PIN NUMBERING CORRESPONDING TO THE BOTTOM ENTRY SOCKET (J2) ON THE USER MOUNTING BOARD. USER MOUNTING BOARDS MUST BE DESIGNED FOLLOWING THIS PIN NUMBERING CONVENTION.

Because the STO Header on the Nano module itself connects to the User Mounting Board via a bottom entry socket, the pin numbering for the header as marked on the Nano module is the mirror image of that for the bottom entry socket on the User Mounting Board.

STO OPERATION

STO Input Voltage	STO State
STO-IN1 AND STO-IN2 ≥ 3.0 Vdc	STO Inactive. Drive can be enabled to produce torque.
STO-IN1 OR STO-IN2 ≤ 2.0 Vdc	STO Active. Drive cannot be enabled to produce torque.
STO-IN1 OR STO-IN2 Open	

Note: Voltages in the STO Operation table are referenced between STO_INx and STO_INx_RTIN in J2. For example, $V(STO1_IN) = V(STO_IN1) - V(STO_IN1_RTIN)$

DIGITAL COMMAND INPUTS: POSITION

STAND-ALONE MODE DIGITAL POSITION-CONTROL INPUTS

NES works with motion controllers that output pulses to command Position. The following formats are supported:

- Step/Direction
- Count-Up/Count-Down (CU/CD)
- A/B Quadrature Encoder

In Step/Direction mode, a pulse-train controls motor Position, and the Direction is controlled by a DC level at the Direction input. CU/CD (Count-Up/Count-Down) signals command the motor to move CW or CCW depending on which input the pulse-train is directed to. The motor can also be operated in an electronic gearing mode by connecting the inputs to a quadrature encoder on another motor. In all cases, the ratio between input pulses and motor revolutions is programmable.

STEP/DIRECTION INPUTS

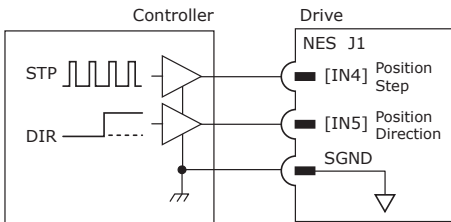

COUNT-UP/COUNT-DOWN INPUTS

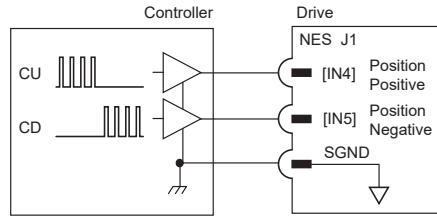

QUAD A/B ENCODER INPUTS

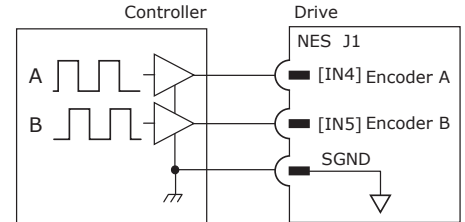

Command Options	Name	J1 Pins
Step, Count Up, Encoder A	IN4	8
Direction, Count Down, Encoder B	IN5	9

J1 SGND Pins
3,4,11,12,33,34,49,50

DIGITAL COMMAND INPUTS: VELOCITY, TORQUE

STAND-ALONE MODE DIGITAL VELOCITY-TORQUE INPUTS

NES works with motion controllers that output pulses to command Velocity or Torque. The following formats are supported:

- Pulse/Direction
- PWM 50%

In Pulse/Direction mode, a pulse-train with variable duty cycle on IN4 controls Velocity or Torque from 0~100%.

IN5 HI or LO controls the direction of the Velocity or polarity of the Torque.

In 50% PWM mode, a single signal of 50% duty cycle commands 0% Velocity/Torque.

Increasing the duty cycle to 100% commands positive Velocity/Torque.

Decreasing the duty cycle to 0% commands negative Velocity/Torque.

PWM & DIRECTION

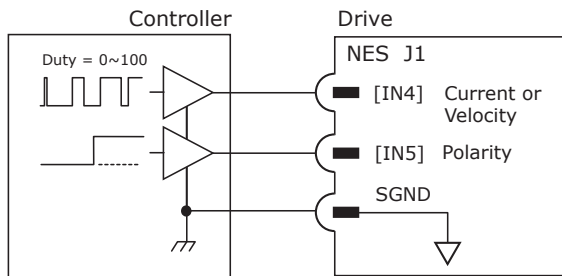

50% PWM

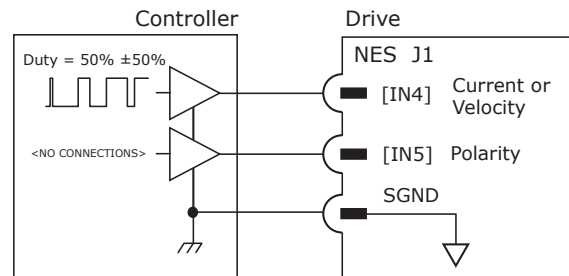

Command Options	Name	J1 Pins
PWM Vel/Trk, PWM Vel/Trk & Direction	IN4	8
PWM/Dir Polarity, (none)	IN5	9

HIGH SPEED INPUTS: IN1, IN2, IN3, IN4, IN5

The six digital inputs to the NES are programmable to a selection of functions. All have 100 ns RC filters when driven by active sources (CMOS, TTL, etc.) and all have 10 kΩ pull-up resistors to +5 Vdc. In addition to the selection of functions, the active level for each input is individually programmable. Input level functions have programmable HI or LO to activate the function. Input transition functions are programmable to activate on LO -> HI, or HI -> LO transitions.

INPUT LEVEL FUNCTIONS

- Drive Enable, Enable with Clear Faults, Enable with Reset
- PWM Sync
- Positive Limit Switch
- Negative Limit Switch
- Home Switch
- Encoder Fault
- Motor Temperature Sensor Input
- Motion Abort
- High-Resolution Analog Divide

INPUT TRANSITION FUNCTIONS

- Clear Faults and Event Latch
- Drive Reset
- PWM Sync Input
- Trajectory Update
- Count Input Edges, Save to Register
- High-Speed Position Capture
- Simulated Absolute Encoder Burst
- Abort Move if > N Counts From Destination in Register

SPECIFICATIONS

Input	Data	Notes
Input Voltages	HI	$V_T + = 1.42 \sim 2.38$ Vdc
	LO	$V_T + = 0.68 \sim 1.6$ Vdc
	Hys	$V_H = 0.44 \sim 1.26$
	Max	+12 Vdc
	Min	0 Vdc
Pull-up	R1	10 kΩ
	R2	1 kΩ
Low pass filter	C1	100 pF
	RC	IN1~5: 0.1 μs
		IN6: 33 us

CONNECTIONS

Name	J1 Pins
IN1	5
IN2	6
IN3	7
IN4	8
IN5	9

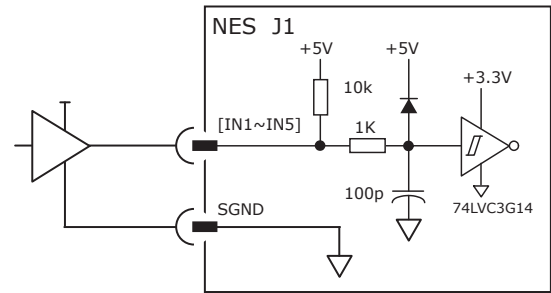

J1 SGND Pins
3,4,11,12,33,34,49,50

WARNING

Consult Factory for Adapting 24V logic to 5V logic.

5V logic. Do not exceed 12V. Do not connect a 24V logic to this input.

MOTOR OVERTEMP INPUT: IN6

Input IN6 has a 33 microsecond rise time RC filter when driven by active sources (CMOS, TTL, etc), with a 4.99 kΩ pullup resistor to +5 VDC. Input IN6 is designed to interface with an industry standard PTC thermistor IAW BS 49990111(1987) for built-in thermal protection of the motor as a default. If it is not used for the Motemp function, IN6 can be re-programmed for other input functions.

CONNECTIONS

Name	J1 Pins
IN6	10

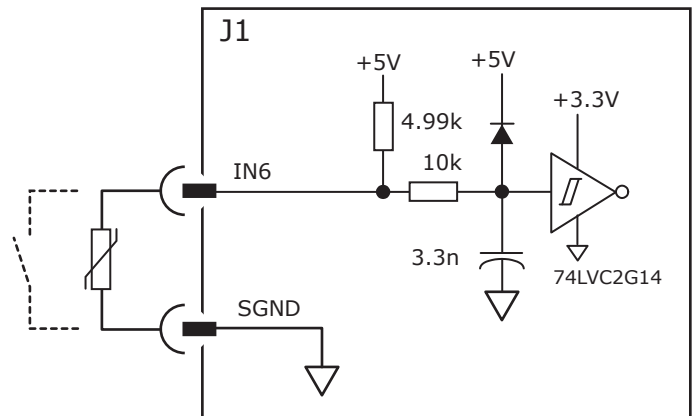

ANALOG INPUT: AIN1

As a reference input, it takes Position/Velocity/Torque commands from a controller. If it is not used as a command input, it can be used as general-purpose analog input.

SPECIFICATIONS

Specifications	Data	Notes
Input Voltage	Vref	±10 Vdc
Input Resistance	Rin	5.0 kΩ

Name	J1 Pins
Ref(+)	2
Ref(-)	1

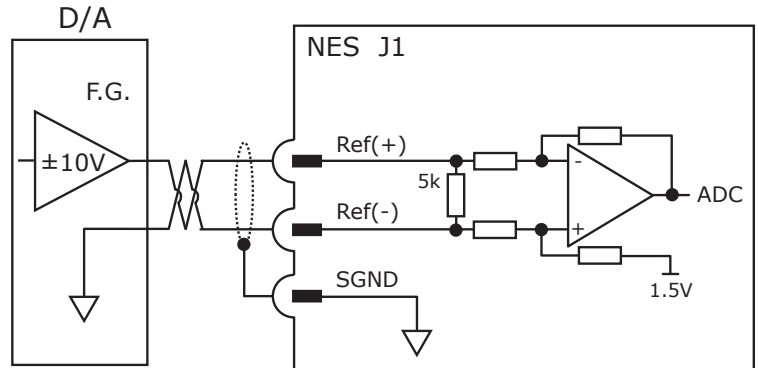

DIGITAL OUTPUTS: OUT1~OUT4

Digital outputs [OUT1~4] are CMOS inverters. They operate from +5V and can source/sink ±4 mA. The output functions shown below are programmable to turn the output On (HI) or Off (LO) when active.

OUTPUT FUNCTIONS

- Fault
- Custom event
- PWM Sync
- Custom Trajectory status
- Custom position-triggered output
- Program control
- Brake control (see Brake Output: OUT4))

Name	J1 Pins
OUT1	13
OUT2	14
OUT3	15
OUT4	16

J1 SGND Pins
3,4,11,12,33,34,49,50

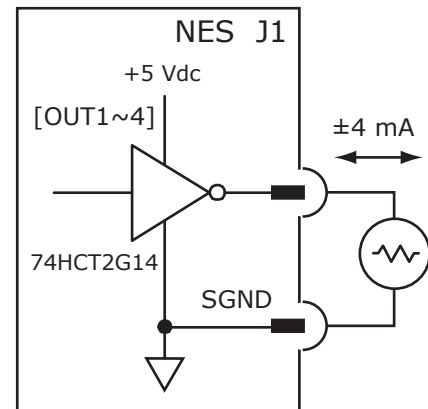

BRAKE OUTPUT: OUT4

The default function of OUT4 is used to control a motor holding brake using the NES-D that has components to sink the higher current of the brake. If it is not used for the brake control, it can be programmed as a logic output.

OUTPUT FUNCTION

- Motor holding brake when NES is mounted to an DEV PCB.
- Same functions as OUT1~OUT3 if drive is used without DEV PCB.

Name	J1 Pins
OUT4	16

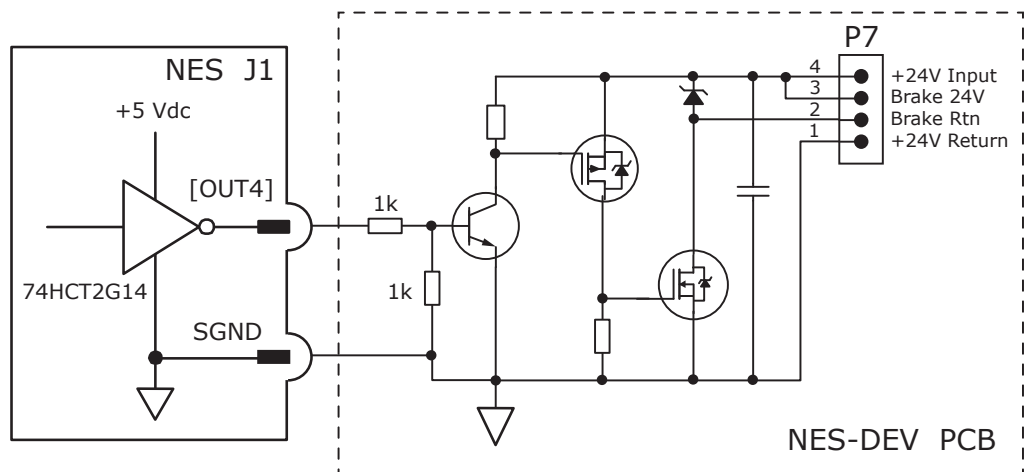

ENCODER 1 (PRIMARY FEEDBACK)

QUAD ENCODER WITH INDEX

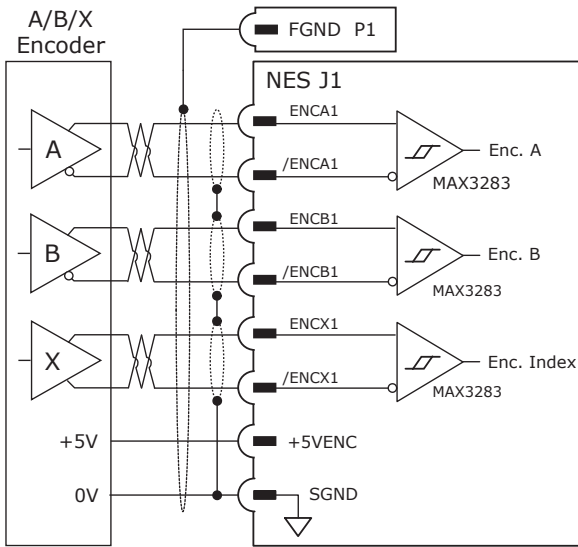

A/B/X SIGNALS

Name	J1 Pins
ENCA1	43
/ENCA1	44
ENCB1	45
/ENCB1	46
ENCX1	47
/ENCX1	48
+5VENC	57,59

FRAME GROUND
P1

J1 SGND Pins
3,4,11,12,33,34,49,50

SSI ABSOLUTE ENCODER

The SSI (Synchronous Serial Interface) is an interface used to connect an absolute position encoder to a motion controller or a control system. The NES drive provides a train of clock signals in differential format to the encoder which initiates the transmission of the position data on the subsequent clock pulses. The number of encoder data bits and counts per motor revolution are programmable. The hardware bus consists of two signals: SCLK and SDATA. The SCLK signal is only active during transfers. Data is clocked in on the falling edge of the clock signal.

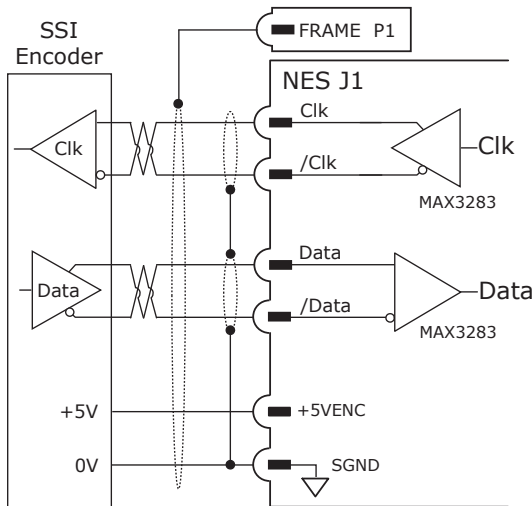

SSI, BiSS SIGNALS		
SSI	BiSS	J1 Pins
Clk	MA+	47
/Clk	MA-	48
Data	SL+	43
/Data	SL-	44
+5V		57,58

BiSS-C ABSOLUTE ENCODER

BiSS-C is an - Open Source - digital interface used for sensors and actuators. BiSS-C refers to principles that comply with industrial standards for Serial Synchronous Interfaces like SSI, AS-Interface® and Interbus® with additional options.

- Serial Synchronous Data Communication
- Cyclic at high speed
- 2 unidirectional lines Clock and Data
 - Line delay compensation for high speed data transfer
 - Request for data generation at slaves
 - Safety capable: CRC, Errors, Warnings
 - Bus capability incl. actuators
- Bidirectional
 - BiSS C-protocol: Continuous mode

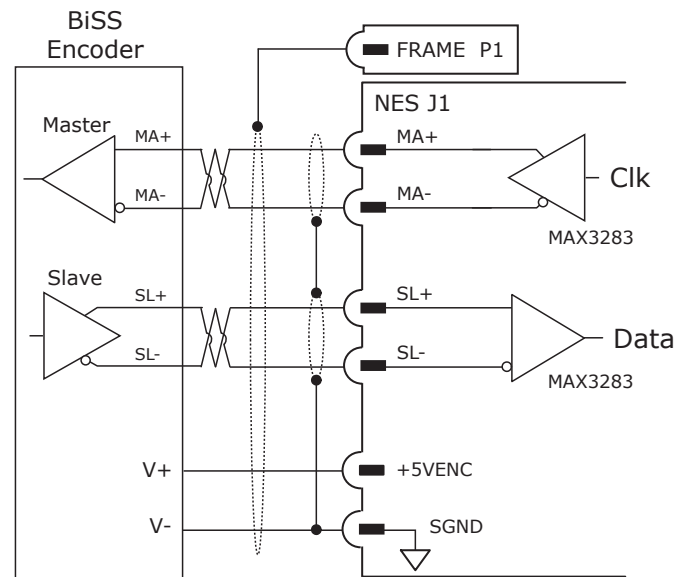

Note: Single (outer) shields should be connected at the drive end. Inner shields should only be connected to Signal Ground on the drive.

ENCODER 2: SECONDARY FEEDBACK

QUAD ENCODER WITH INDEX

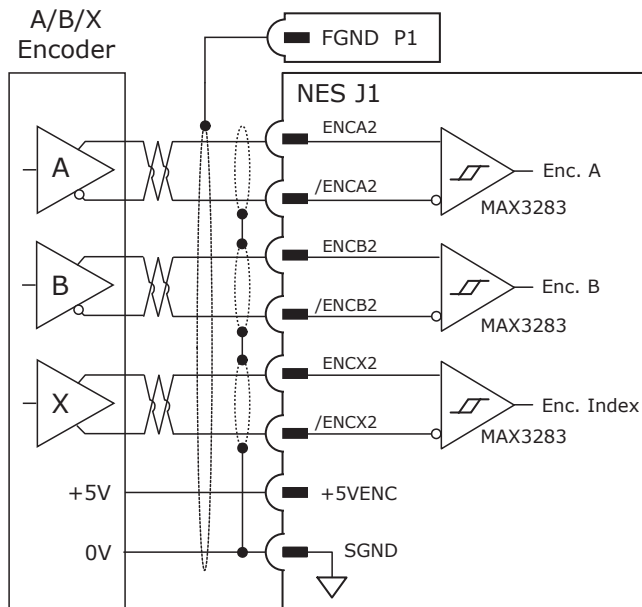

A/B/X SIGNALS

Signal	J1 Pins
ENCA2	51
/ENCA2	52
ENCB2	53
/ENCB2	54
ENCX2	55
/ENCX2	56
+5VENC	57,59

FRAME GROUND
P1

J1 SGND Pins
3,4,11,12,33,34,49,50

Note: The secondary encoder supports only A/B/X incremental encoders.

OTHER MOTOR CONNECTIONS

HALLS

Hall sensors in a brushless motor are driven from the magnetic field in the motor and provide commutation feedback without an encoder. When the sensors are used with incremental encoders, they enable the motor to operate without a phase-finding cycle.

HALL SIGNALS

Signal	J1 Pins
HALLU	39
HALLV	40
HALLW	41

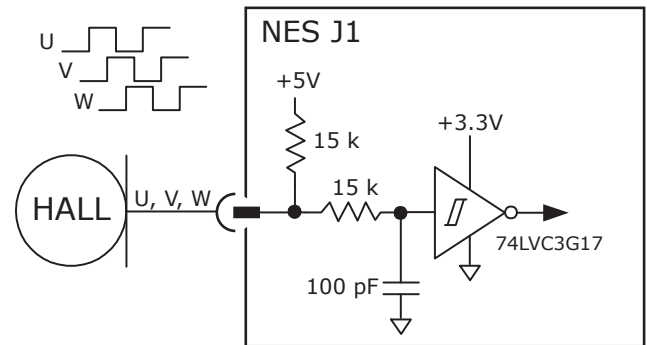

DC OUTPUT VOLTAGES

+5VENC

This voltage is used for encoders and has internal fault protection. The maximum current output is 500 mA shared between encoders. Current limiting occurs at 600 mA minimum, 1.0 A maximum.

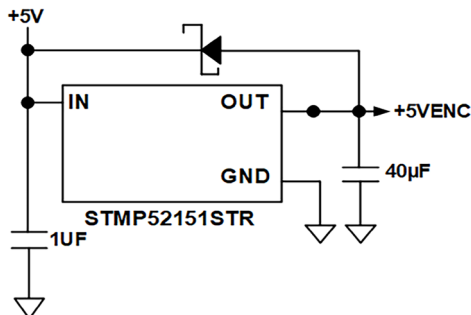

+5V

This voltage is used for optional peripherals immediately adjacent to the module and it has an internal fault protection. The maximum current output is 150 mA.

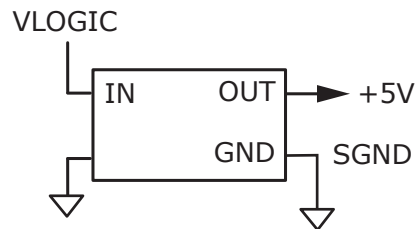

+3.3 VDC

For connections immediately adjacent to the module, use the following:

- Microcontroller
- RS-232 Transceiver
- CAN Transceiver
- LEDs, and Address Switches
- (150 mA maximum)
- Protected for overload or shorts

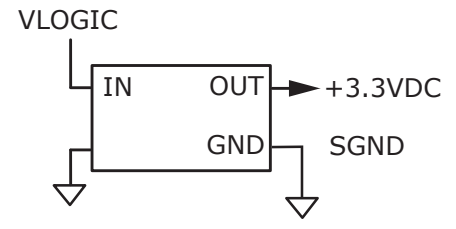

+HV CONNECTIONS

POWER SUPPLIES

The drive main power, +HV, is typically supplied by unregulated DC power supplies. These power supplies must be isolated from the mains, and all circuits should be grounded to earth at some point. The +HV supply connects to P5 and P6.

To comply with the wiring practices, the +HV wires should be twisted together for noise suppression, and the power supply should not be grounded. By following the wiring guidelines, it ensures that the higher currents flowing in these conductors will not flow through any circuit grounds where they might induce noise.

During deceleration, the mechanical energy in the motor and load is converted back into electrical energy that must be dissipated as the motor comes to a stop. While some of this is converted to heat in the motor windings, the rest of it will flow through the drive into the power supply.

Use an external storage capacitor if the load has appreciable inertia. This should be sized, so that adding the undissipated energy from the motor will not raise the voltage beyond the point at which the drive shuts down. When this is not possible, an external 'dumper', or regenerative energy dissipater must be used which acts as a shunt regulator across the +HV and Gnd terminals.

GROUNDING

A P6 connection to ground keeps the +HV power source stable at the drive while the voltage at the power supply (-) varies due to the cable resistance and the +HV current. Grounding at P1 provides a PE (Protective Earth) connection as well as a point to ground the motor cable shields.

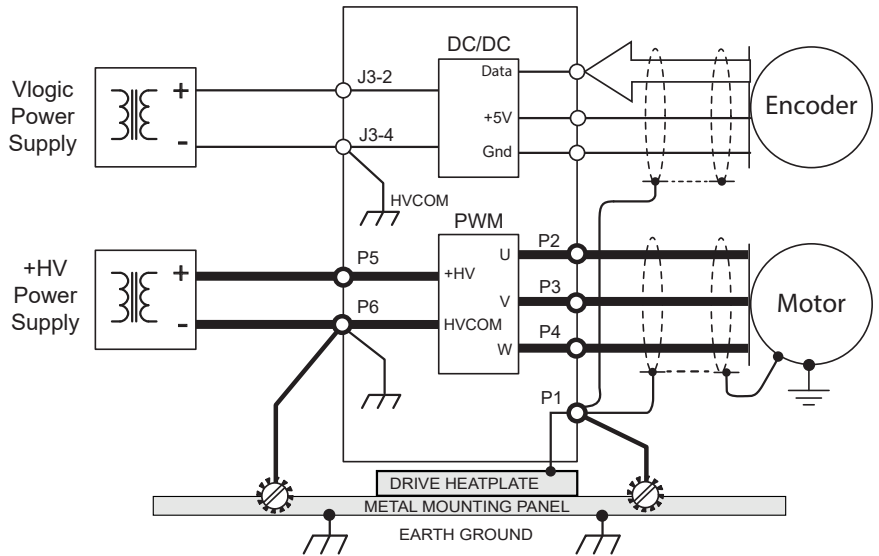

P1~P6

Signal	Pins
FGND	P1
MOTU	P2
MOTV	P3
MOTW	P4
+HV	P5
HVCOM	P6

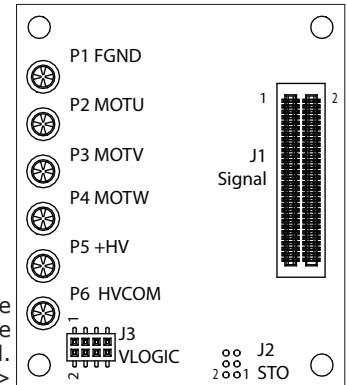

Note: The diagram shows the top-view looking into the user mounting board.

VLOGIC CONNECTIONS

DESCRIPTION

VLOGIC is required for operation of the drive. It powers the internal logic and control circuits. Encoder +5V is derived from VLOGIC. When the STO feature is used, VLOGIC must be produced by power supplies with a transformer isolation from the mains and PELV or SELV ratings, and a maximum output voltage of 60 Vdc. If the motor can operate from voltages of 60 Vdc or less, the +HV and VLOGIC can be driven from a single power supply.

J3 VLOGIC

Name	Pin	Name
N.C.	2	1
N.C.	4	3
VLOGIC	6	5
VLOGIC	8	7

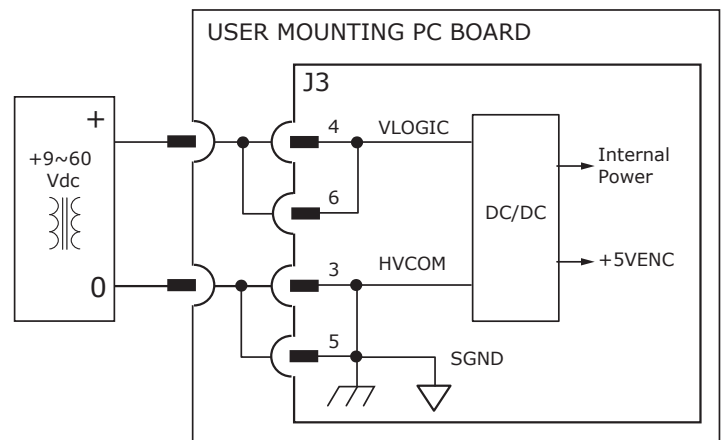
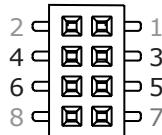

Refer to the AN136 Accelnet External Regen Application Note, Part Number 16-125661.

VLOGIC +9~60. 24V power is recommended. 24V required if using 24V BRAKE. If common to HV do not exceed 60V, use REGEN protection, and diode isolation from HV.

NES TYPICAL CONNECTIONS

The following diagram shows the NES connections.

Note: In the diagram, the asterisk indicates the user is required to supply the resistors on the driving mounting board.

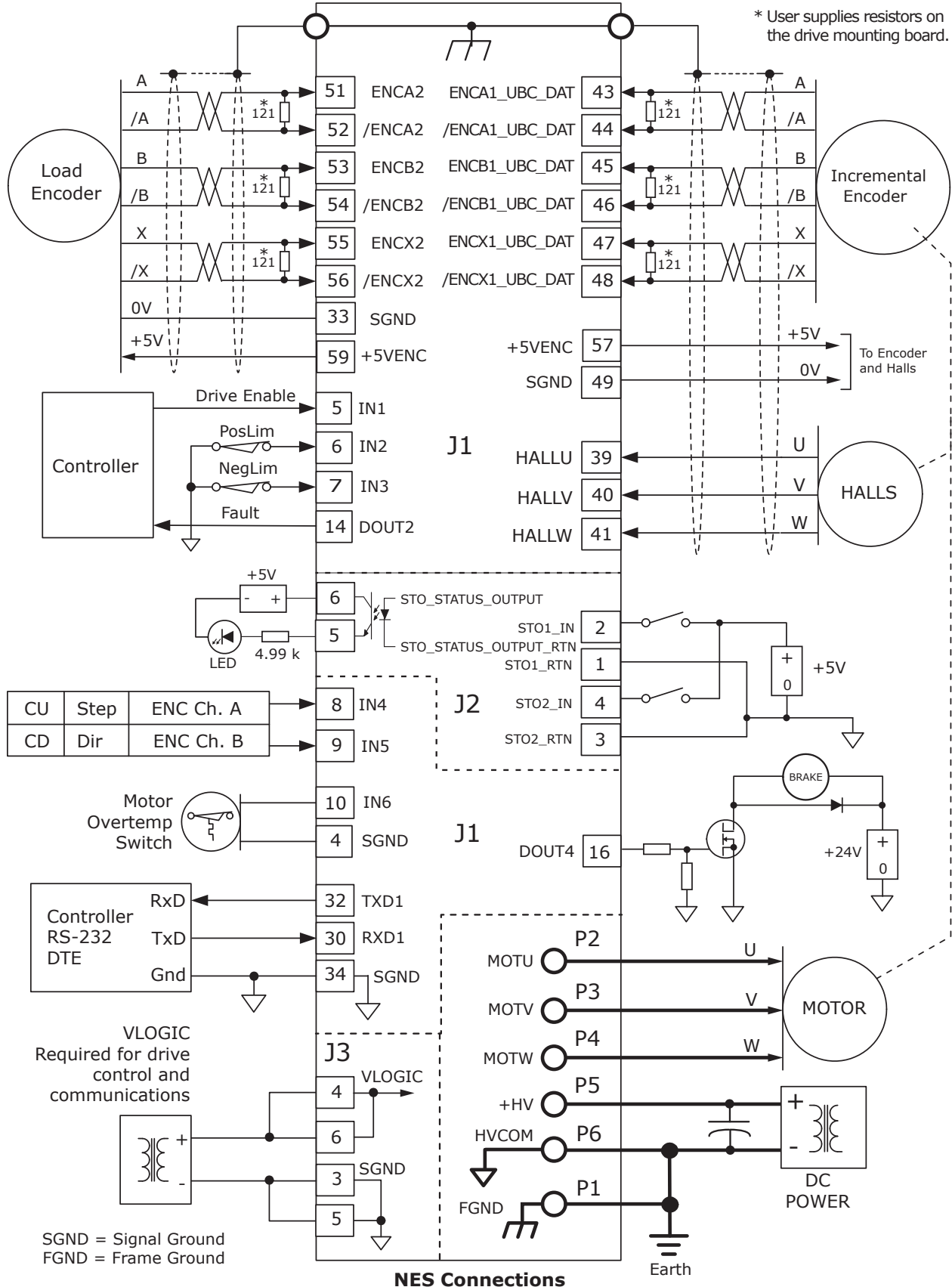

PC BOARD CONNECTIONS

The following diagrams and tables show the pins and signals located on the topside of the user mounting board.

Name	Pin
FGND	P1
Mot U	P2
Mot V	P3
Mot W	P4
+HV	P5
HVCOM	P6

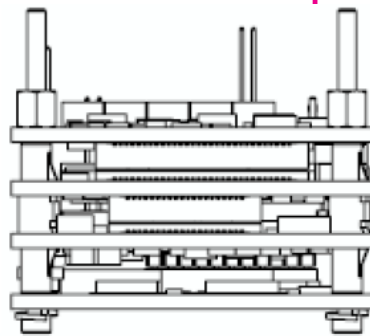
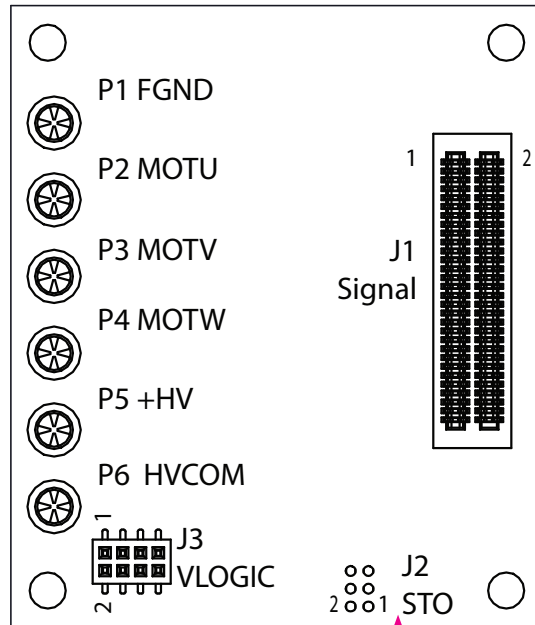

J2 STO Connector Diagram

J3 VLOGIC

Name	Pin	Name
N.C.	2	1
VLOGIC	4	3
	6	5
N.C.	8	7

J2 STO CONNECTIONS

Name	Pin	Name
STO_STATUS_OUTPUT	6	5
STO2_IN	4	3
STO1_IN	2	1

Note: The STO Connector J2 is mounted on the bottom side of the PCB.

ALL PIN NUMBERING INFORMATION FOR MODULE-LEVEL STO CONNECTIONS IN THIS DOCUMENT IS PIN NUMBERING CORRESPONDING TO THE BOTTOM ENTRY SOCKET (J2) ON THE USER MOUNTING BOARD. USER MOUNTING BOARDS MUST BE DESIGNED FOLLOWING THIS PIN NUMBERING CONVENTION.

Because the STO Header on the Nano module itself connects to the User Mounting Board via a bottom entry socket, the pin numbering for the header as marked on the Nano module is the mirror image of that for the bottom entry socket on the User Mounting Board.

J1 SIGNAL

Name	Pin	Name
REFIN1-	1	2
AGND	3	4
[ENABLE] IN1	5	6
IN3	7	8
IN5	9	10
SGND	11	12
DOUT1	13	14
DOUT3	15	16
SGND	17	18
+3.3V_TXRX1	19	20
+3.3V_TXRX2	21	22
[Tx2-] TXNB	23	24
[Tx2+] TXPB	25	26
[Rx2-] RXNB	27	28
[Rx2+] RXPB	29	30
SGND	31	32
SGND	33	34
ASYNC_RXD2	35	36
ASYNC_TXD2	37	38
HALLU	39	40
HALLW	41	42
ENCA1_UBC_DAT	43	44
ENCB1	45	46
ENCX1_UBC_CLK	47	48
SGND	49	50
ENCA2	51	52
ENCB2	53	54
ENCX2	55	56
+5VENC	57	58
+5VENC	59	60

Note: In the table, the term, N.C., refers to No Connection.



PC BOARD CONNECTORS

**User Mounting Board
Topside View**

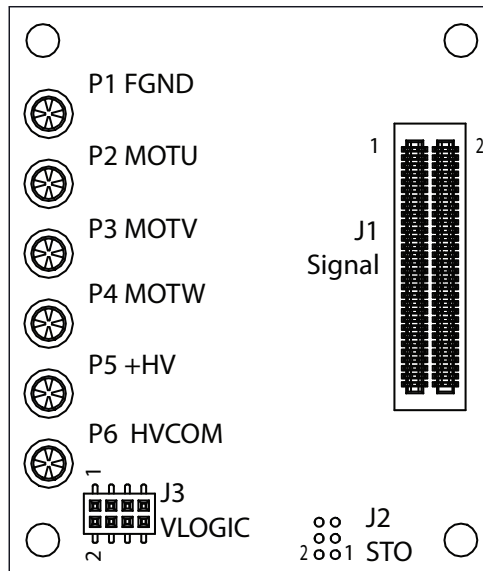

**User Mounting Board
Underside View**

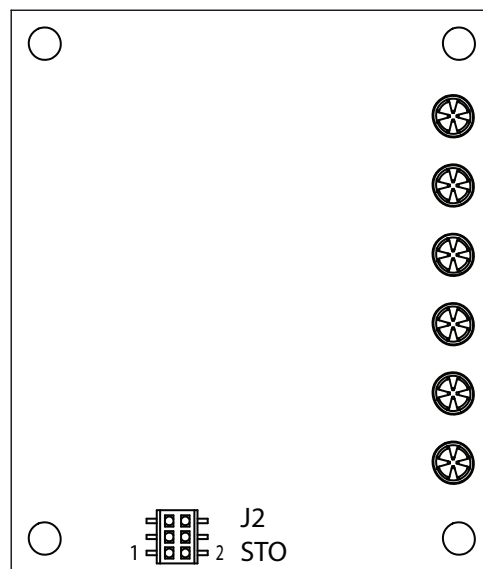

Ref Des	Label	Mfgr	Part Number *	Description	QTY
J1	Signal	WCON	3620-S060-022G3R02	Header, 60 pos, 0.5 mm pitch	1
J2	STO	Samtec	CLM-103-02-L-D-BE	Header, 6 pos, 1 mm pitch	1
J3	VLOGIC	WCON	2521-204MG3CUNR1	Header, 8 pos, 1 mm pitch	1
P1~P6	+HV, Motor	WINPIN	WP-WJ018G3R1	RCPTL Outer Sleeve Crown Spring	6

*Note: In the table, the asterisk indicates the part numbers to purchase reels of these components. Refer to the following vendor to contact for approved value-added partner Action Electronics.

Action Electronics, Inc.
Walpole, MA 02081-2522-US
Phone: (508) 668-5621

DIMENSIONS

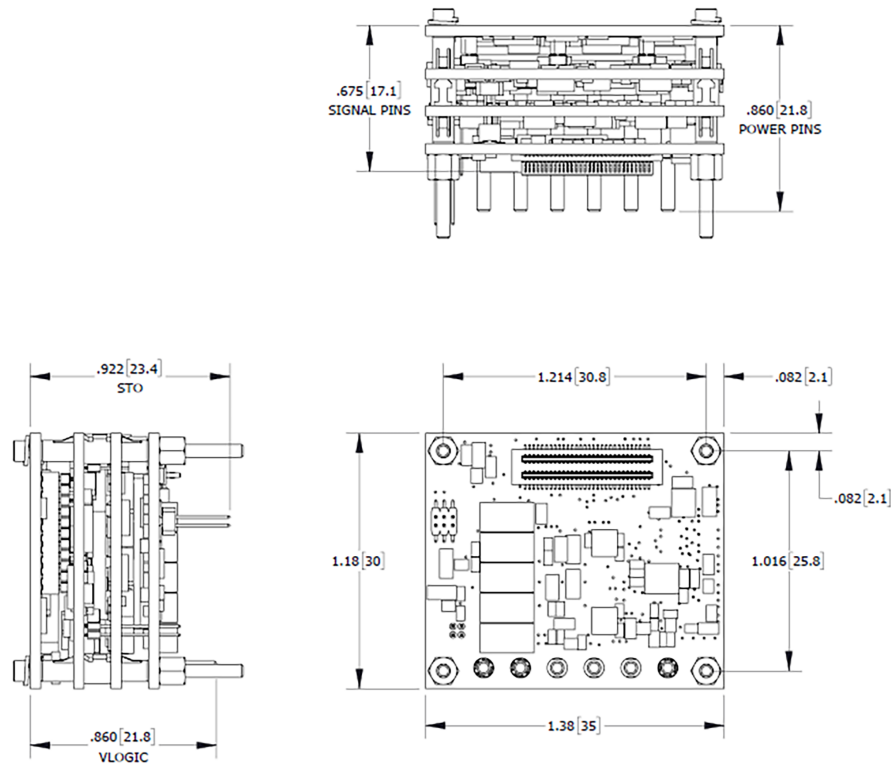

Dimensions are in Inches [mm]

PC BOARD MOUNTING DIMENSIONS

The following diagram shows the topside view of the user mounting PC board for the drive. The STO J2 connector is mounted on the underside of the PC board. The topside view shows the clearance holes for the STO connector mating pins.

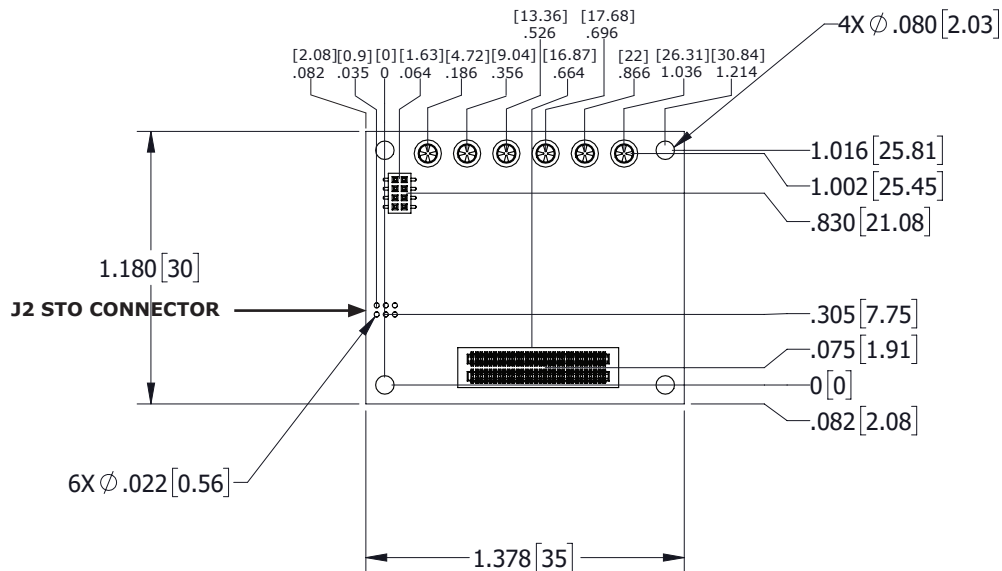

User Mounting Board Dimensions (Topside View)

THERMALS: PWM OUTPUTS DISSIPATION

NES-090-70

The following chart shows the power dissipation in the drive when the PWM outputs are driving a motor. Adding the PWM dissipation to the Vlogic dissipation will yield the total dissipation in Watts for the drive. In the chart, the dotted lines show a dissipation of 18 W. at a continuous current of 28 Adc and +HV = 85 Vdc.

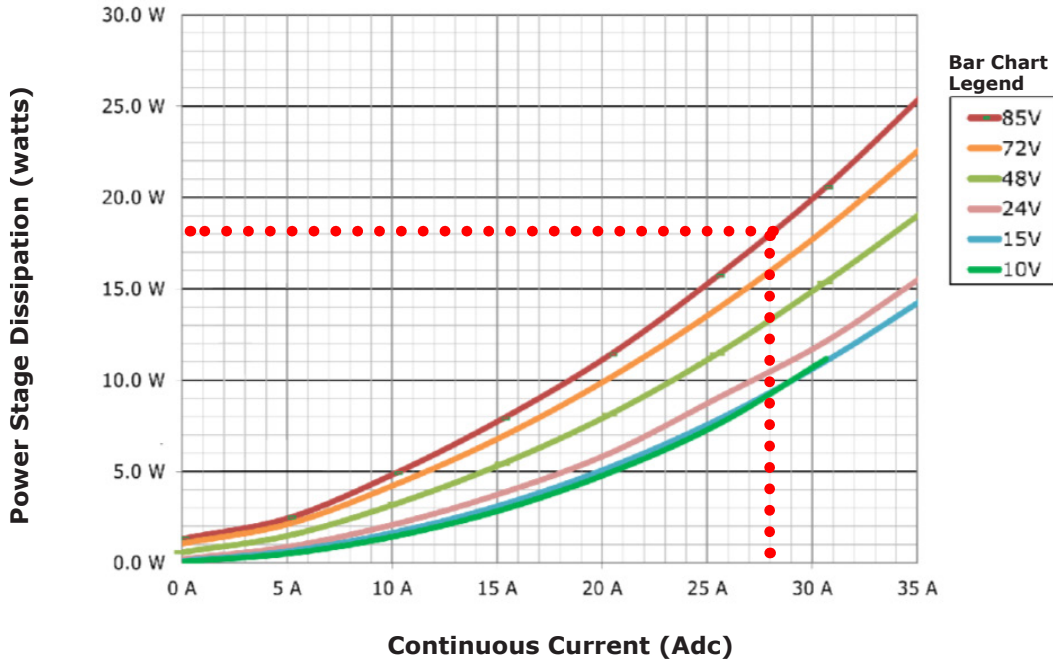

NES-180-10

The following chart shows the power dissipation in the drive when the PWM outputs are driving a motor. Adding the PWM dissipation to the Vlogic dissipation will yield the total dissipation in Watts for the drive. In the chart, the dotted lines show a dissipation of 5.2 W. at a continuous current of 4.4 Adc and +HV = 180 Vdc.

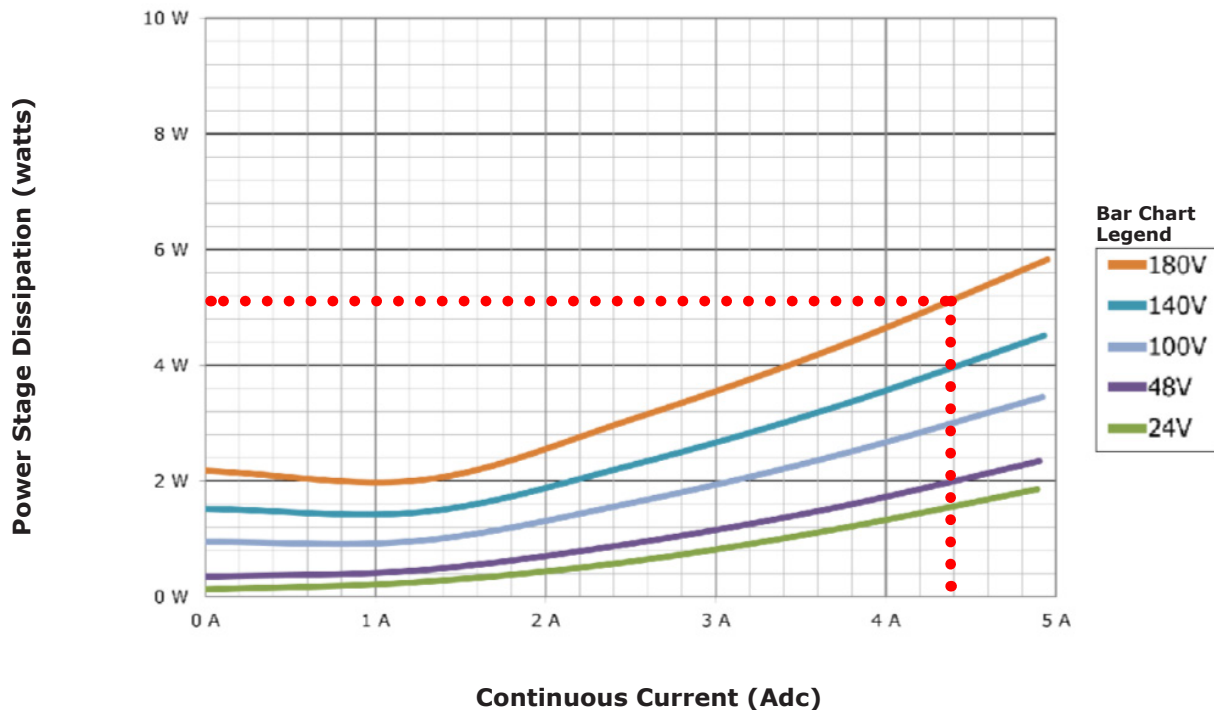

NES-180-30

In the chart below, it shows the power dissipation in the drive when the PWM outputs are driving a motor. Adding the PWM dissipation to the Vlogic dissipation will yield the total dissipation in Watts for the drive. In the chart, the dotted lines show a dissipation of 20 W. at a continuous current of 13 Adc and +HV = 180 Vdc.

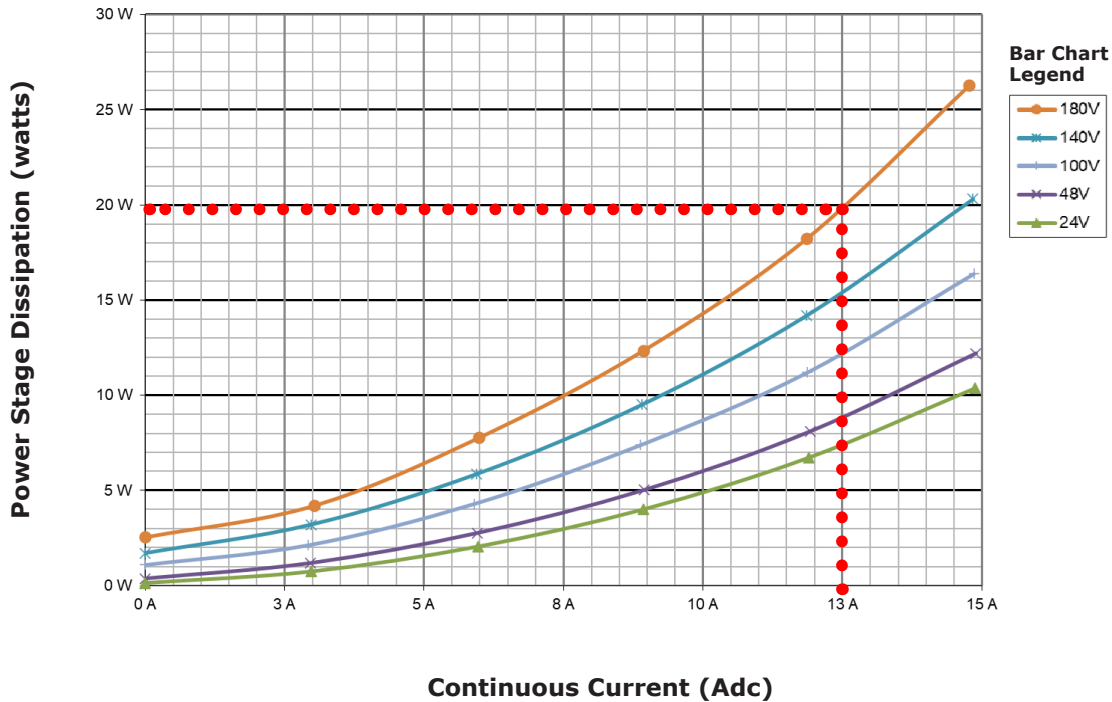

NES All Models

In the chart below, it shows the power dissipation in the Vlogic circuits that power the drive’s control circuits and the external encoders. Adding the PWM dissipation to the Vlogic dissipation will yield the total dissipation in Watts for the drive. In the chart, the dotted lines show a dissipation of 3.0 W. at Vlogic = 30 Vdc, when the drive is in an Enabled state and outputting 250 mA for an encoder.

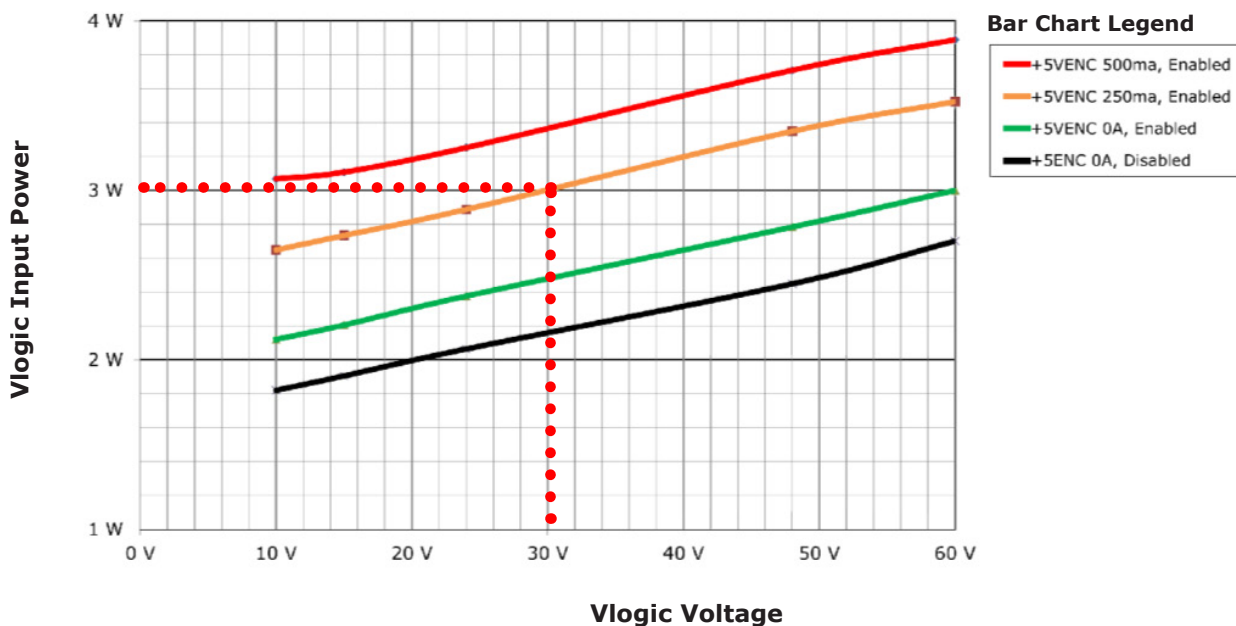

THERMAL RESISTANCE

In the Heatsink table, it shows the thermal resistance Rth in degrees-C per Watt (C/W) for typical cooling configurations. The drive has the standard "pins" heatsink mounted with a sheet of thermal material placed between the drive and the heatsink.

The acronym, LFM, is Linear Feet per Minute. LFM is defined as the velocity of air flow produced by a fan directed in line with the heatsink fins.

HEATSINK

LFM	0	100	200	300	400
Rth	5.3	3	2.5	1.6	1.3

FIND COOLING MEANS WITH DISSIPATION AND AMBIENT TEMPERATURE KNOWN

Given: Tamb = 32 °C (89.6 °F), PWM dissipation = 18 W, VLOGIC dissipation = 3 W
 Tmax = 80 °C (drive shut-down temperature minus 10 °C for margin)

Find: Thermal Resistance Rth:
 Delta-T = Tmax - Tamb = 80 - 32 = 48 °C
 Total dissipation = 18 + 3 = 21 W
 Rth = Delta-T / dissipation = °C / Watt = 48 / 21 = 2.3 °C/W

From the above table, there is one configuration that provides Rth less than 2.3 °C/W:
 With heat sink, forced air at 300, 400 LFM

FIND MAX AMBIENT TEMP WHEN DRIVE CONFIGURATION IS KNOWN

Given: Heatsink, forced-air at 300 LFM, dissipation is 26.5 W
 Rth = 1.6 °C/W
 Tmax = 80 °C (drive shut-down temperature)

Find: Max ambient operating temperature
 Delta-T = 26.5 W x 0.9 °C/W = 23.9 °C
 Max. Tamb = Tmax - Delta-T = 80 - 23.9 = 56.1 °C
 Max. ambient operating temperature is 45 °C so it can operate up to this temperature.

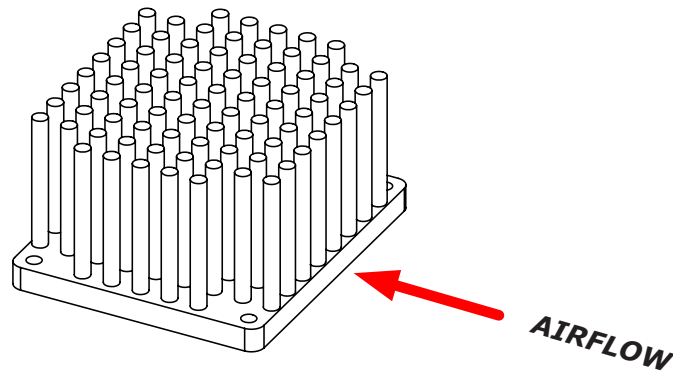

Airflow Direction

NES-D

MODEL	Ic	Ip	Vdc
NES-090-10-D	5	10	9~90
NES-090-70-D	35	70	9~90
NES-180-10-D	5	10	20~180
NES-180-30-D	15	30	20~180

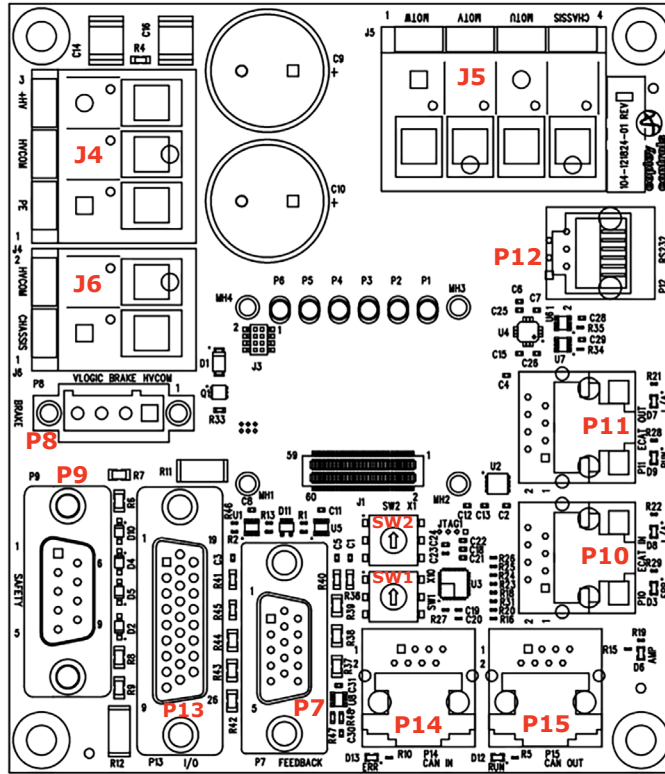

J4 +HV

Signal	Pin
+HV	3
HVCOM	2
PE	1

J6 GROUNDS

Signal	Pin
HVCOM	2
FGND	1

P8 BRAKE

Signal	Pin
24V_GND_IN	1
BRAKE	2
VLOGIC	3
VLOGIC	4

P9 STO

Signal	Pin	Signal
FGND	1	6 STO_STATUS_OUTPUT
STO1_24V_IN	2	7 STO_STATUS_OUTPUT_RTN
STO1_RTN	3	8 SGND
STO2_24V_IN	4	9 VLOGIC +24V
STO2_RTN	5	

P7 ENCODER 1

Pin	Signal	Pin	Signal	Pin	Signal
1	FGND	6	HALLV	11	/ENCB1
2	+5VENC	7	/ENCX1_UBC_CLK	12	ENCB1
3	HALLU	8	ENCX1_UBC_CLK	13	/ENCA1_UBC_DAT
4	+5VENC	9	HALLW	14	ENCA1_UBC_DAT
5	SGND	10	OVERTEMP_IN	15	SGND

P13 I/O & ENCODER 2

Pin	Signal	Pin	Signal	Pin	Signal
1	FGND	10	IN5	19	SGND
2	REFIN1-	11	N.C.	20	+5VENC
3	REFIN1+	12	N.C.	21	/ENCX2
4	IN1_24VTOL	13	N.C.	22	ENCX2
5	IN2_24VTOL	14	N.C.	23	/ENCB2
6	IN3_24VTOL	15	SGND	24	ENCB2
7	IN4	16	DOUT1	25	/ENCA2
8	N.C.	17	DOUT2	26	ENCA2
9	N.C.	18	DOUT3		

J5 MOTOR

Pin	Signal
1	MOTW
2	MOTV
3	MOTU
4	FGND

P12 RS-232

Pin	Signal
6	N.C.
5	TxD
4	SGND
3	SGND
2	RxD
1	N.C.

P10 ECAT IN

Pin	Name
8	FGND
7	N.C.
6	RXNA [RX1-]
5	VDD33TXRX1
4	RXPA [R1+]
3	TXNA [TX1-]
2	VDD33TXRX1
1	TXPA [TX1+]

P11 ECAT OUT

Pin	Name
8	FGND
7	N.C.
6	RXNB [RX2-]
5	VDD33TXRX2
4	RXPB [RX2+]
3	TXNB [TX2-]
2	VDD33TXRX2
1	TXPB [TX2+]

NES-D ETHERCAT CONNECTORS

ETHERCAT CONNECTORS

Dual RJ-45 connectors that accept standard Ethernet CAT-5 cables are provided for the EtherCAT connectivity.

P10 ECAT-IN

Pin	Signal
1	TX1+
2	
3	TX1-
4	RX1+
5	*
6	RX1-
7	N.C.
8	N.C.

P11 ECAT-OUT

Pin	Signal
1	TX2+
2	
3	TX2-
4	RX2+
5	*
6	RX2-
7	N.C.
8	N.C.

*Note: In the Signal column, the asterisk indicates the corresponding pin connects to the R/C that is inside the ECAT connector.

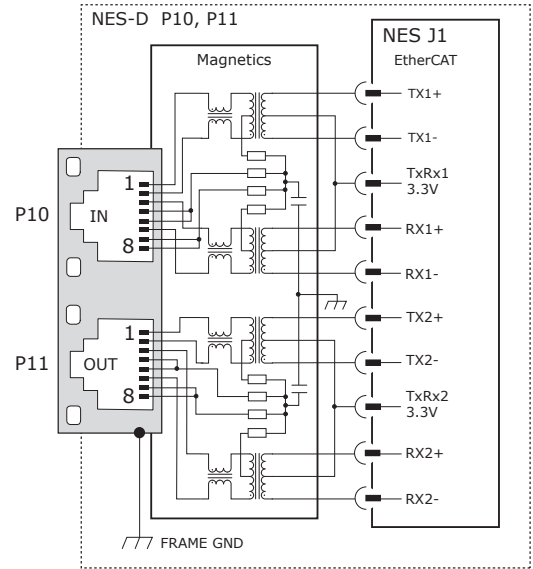

Dual RJ-45 sockets accept standard Ethernet cables. The IN port connects to a master or connects to the OUT port of a device that is 'upstream' between the NES and the master.

The OUT port connects to 'downstream' nodes. If the NES is the last node on a network, only the IN port is used. No terminator is required on the OUT port.

RUN		ERR	
Green shows the EtherCAT State Machine:		Red shows error conditions:	
OFF	= Init State	BLINKING	= Invalid Configuration
BLINKING	= Pre-operational	SINGLE FLASH	= Unsolicited State Change
SINGLE FLASH	= Safe-Operational	DOUBLE FLASH	= Application Watchdog Timeout
ON	= Operational		

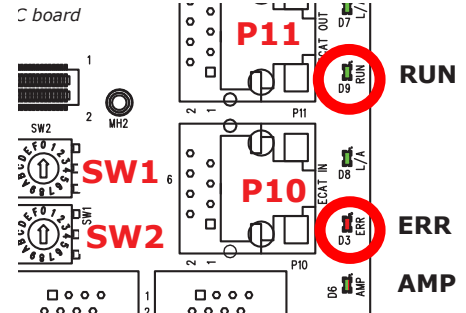

L/A (LINK/ACT)

Green indicates the state of the EtherCAT network.

LED	Link	Activity	Condition
ON	Yes	No	= Port Open
FLICKERING	YES	YES	= Port Open with activity
OFF	No	(N/A)	= Port Closed

EtherCAT DEVICE ID

In an EtherCAT network, slaves are automatically assigned fixed addresses based on their position on the bus. When a device requires a positive identification that is independent of cabling, a Device ID is needed. In the EZ board, Device ID is assigned two, 16-position rotary switches with hexadecimal encoding. These switches can set the Device ID of the drive from 0x01~0xFF (1~255 decimal). In the table, the DEC column includes the decimal values and the HEX column includes the corresponding hex settings for each switch (SW1 and SW2).

For Example 1: To find the switch settings for the Decimal Device ID 107, refer to the table to calculate the following:

- In the table SW1 column, find the highest number that is less than 107, (96). Refer to the SW1 column and set SW1, (96) to the corresponding hex value that appears in the HEX column, (6).
96 < 107 and 112 > 107, so SW1 = 96 = Hex 6
- Subtract 96 from the desired Device ID (107) to get the decimal value of switch SW2, (11). Refer to the SW2 column and set SW2, (11) to the corresponding hex value that appears in the HEX column, (B).
SW2 = (107 - 96) = 11 = Hex B

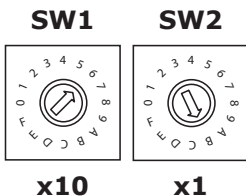

EtherCAT Device ID Switch Decimal Values

HEX	SW1	SW2
	DEC	
0	0	0
1	16	1
2	32	2
3	48	3
4	64	4
5	80	5
6	96	6
7	112	7
8	128	8
9	144	9
A	160	10
B	176	11
C	192	12
D	208	13
E	224	14
F	240	15

NES-D

AMP STATUS LED

A bi-color LED gives the state of the drive. Colors do not alternate, and can be solid ON or BLINKING. If multiple conditions occur, only the top-most condition will be displayed. When that condition is cleared, the next condition in the table will be shown.

LED	Condition Description
RED/BLINKING	Latching fault. Operation can not resume until the drive is Reset.
RED/SOLID	Transient fault condition. Drive can resume the operation when the condition causing the fault is removed.
GREEN/SLOW-BLINKING	Drive OK but NOT-enabled. Can run when enabled.
GREEN/FAST-BLINKING	Positive or Negative limit switch active. Drive can only move in the direction not inhibited by limit switch.
GREEN/SOLID	Drive OK and enabled. Can run in response to reference inputs or EtherCAT commands.

LATCHING FAULTS

Default	Optional (Programmable)
Short circuit (Internal or External)	Over-voltage
Drive over-temperature	Under-voltage
Motor over-temperature	Motor Phasing Error
Feedback Error	Command Input Fault
Following Error	Motor Wiring Disconnected
	Over Current (Latched)

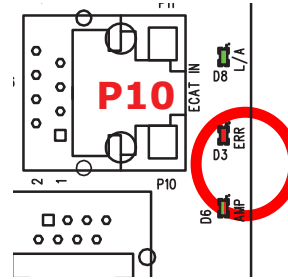

RS-232 CONNECTION

The RS-232 port is used to configure the drive for stand-alone applications, or for configuration before it is installed into an EtherCAT network. CME software communicates with the drive over this link and is then used for a complete drive setup. The EtherCAT Device ID that is set by the rotary switches can be monitored, and a Device ID programmed as well.

The RS-232 connector, P12, is a modular RJ-11 type that uses a 6-position plug, four wires of which are used for RS-232. A connector kit is available (SER-CK) that includes the modular cable, and an adapter to interface this cable with a 9-pin RS-232 port on a computer.

P12 DEV RS-232

Pin	Signal
2	RS232RX1 [RxD]
3,4	SGND
5	RS232TX1 [TxD]

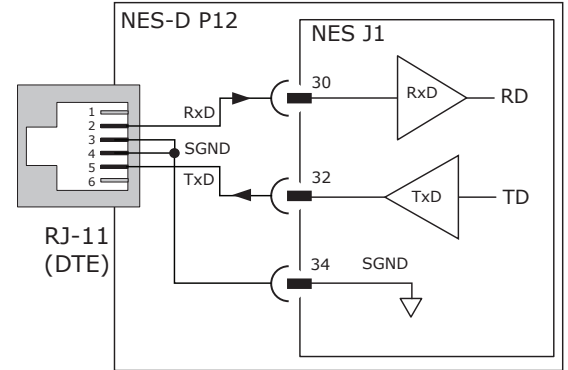

SER-CK SERIAL CABLE KIT

The SER-CK provides connectivity between a D-Sub 9 male connector and the RJ-11 connector P12 on the NES-D. It includes an adapter that plugs into the COM1 (or other) port of a PC and uses a straight-through modular cable to connect to the NES. The connections are shown in the diagram below.

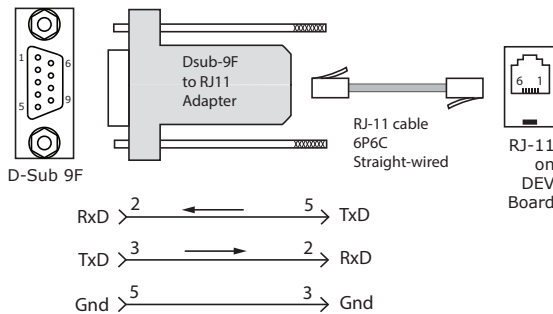

SER-USB-RJ11

This device provides connectivity between a USB connector and the RJ-11 connector J9 on the DEV board.



Note: The Serial Interface Cable USB to RJ11 (SER-USB-RJ11) can be used to plug-into either a customer-designed board with an RJ11 or a Copley NES drive with the NES-D. When you order either type of board, the Manufacturer recommends you order the Serial Interface Cable USB to RJ11 (SER-USB-RJ11).

NES-D SAFE TORQUE OFF (STO)

DESCRIPTION

The following tables and diagrams show the use of external 24V to energize the STO inputs. Both STO inputs must be energized in order to enable the drive.

The hardware Enable input (IN1) is used with an immediate contact relay to bring the motor to a stop before a delayed contact relay de-energizes the STO inputs and prevents torque production in the motor.

STAT-OUT Operation

STO1	0	1	0	1
STO2	0	0	1	1
STAT	0	0	0	1

P9 STO

Signal	Pin	Signal
FGND	1	STO_STATUS_OUTPUT
STO1_24V_IN	2	STO_STATUS_OUTPUT_RETURN
STO1_RTN	3	SGND
STO2_24V_IN	4	VLOGIC
STO2-RTN	5	

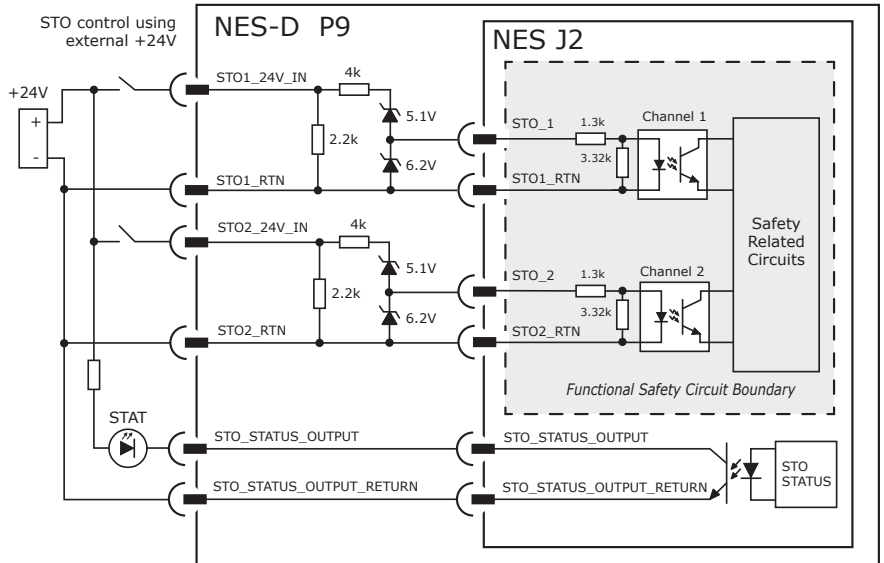

In the STAT-OUT Operation table, the STO1 & STO2 rows, 1 = 24V are applied between the IN-24V and RTN. 0 = open-circuit. In the STAT row, 1 = the optocoupler is ON, 0 = the optocoupler is OFF. STAT output is On (True) when both STO1 & STO2 are energized, allowing the drive to be enabled and to produce torque.

STO OPERATION

STO Input Voltage	STO State
STO1_24V_IN AND STO2_24V_IN \geq 16 Vdc	STO Inactive. Drive can be enabled to produce torque.
STO2_24V_IN OR STO2-IN-24V $<$ 16 Vdc	STO Active. Drive cannot be enabled to produce torque.
STO1_IN OR STO2_IN Open	

Note: In the above table, voltages are referenced between an STOx-IN and an STOx-RTN in P2.
E.g. $V(\text{STO1-IN}) = V(\text{STO1-24V-IN1}) - V(\text{STO1-RTN})$

NES-D SAFE TORQUE OFF (STO) BYPASS

Bypassing is used by users who don't want to use the STO function. The STO-CK-04 has jumpers that use the VLOGIC to energize the STO inputs. This disables the STO function, allowing the drive to be enabled from hardware inputs or a network.

STO-CK-04

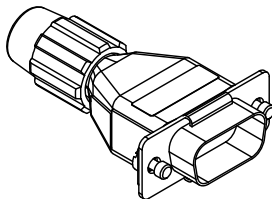

WIRING Diagram

In the diagram, the colored lines are as follows:

- Red = (VLOGIC): 2,4,9
- Blue = (SGND): 3,5,8

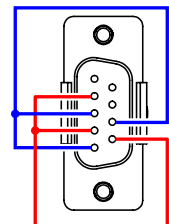
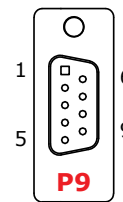

NES-D SWITCHES & LEDS

DEVICE ID SWITCH CONNECTIONS & LEDS

The following diagram shows the connections to the EtherCAT Device ID switches and status LEDs. The switches are read after the drive is reset or powered-On. When changing the settings of the switches, be sure to either reset the drive or power it OFF-ON.

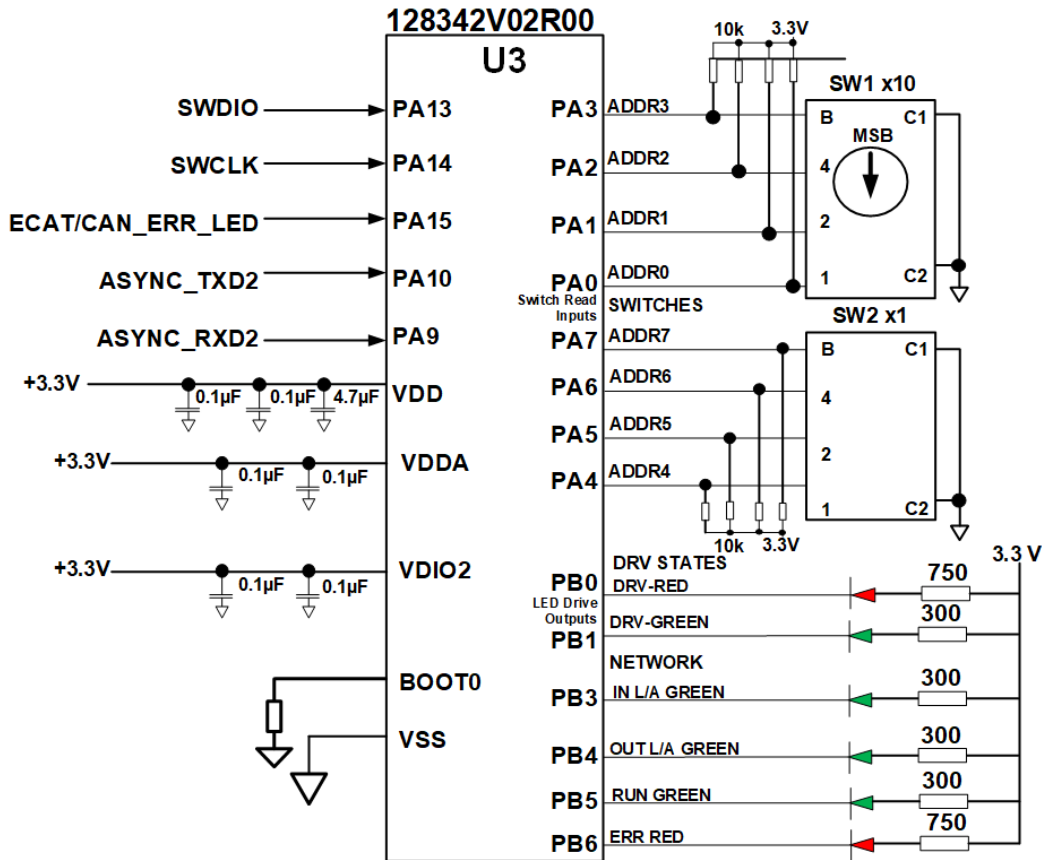

Device ID Switch Connections & LEDS

Ordering Information: U3

In the above diagram, U3 can be purchased through the Copley approved supplier, Arrow Electronics.

Contact Information:

Arrow Electronics
4 Technology Drive
Peabody, MA 01960
Phone: (978) 538-8500

Refer to the table below for more details.

Part Number	Supplier	Description
128342V02R00	Arrow Electronics	Pre-programmed uC for Address Switch and LED

NES-D +HV, VLOGIC, & MOTOR CONNECTIONS

J4 +HV

The +HV power supply connects to J4 pins 2 and 3. In the diagram, the shield shown is optional and is primarily used for the reduction of RF emissions from the drive. As shown, it connects to the case of the power supply. Note that the minus terminal is not grounded externally. This is because currents in the cables produce voltage drops. Grounding the supply at the drive ensures that such voltage drops do not appear in the drive circuits.

J5 MOTOR

Pins 1~3 are used for the motor windings. Pin 4 is used for a cable shield. It connects to the drive heatplate on one end and should connect to the motor frame on the other end. This provides a return path for currents produced by the PWM outputs and the capacitance between the cable conductors, motor windings, and motor frame. While the frame is commonly grounded by mounting to equipment, without the shield connections, the PWM shield current could flow into external devices.

P8 VLOGIC

P8 powers the internal logic and control circuits in the drive. When the STO feature is used, it must be produced by power supplies with the transformer isolation from the mains and PELV or SELV ratings, and it produces a maximum output voltage of 60 Vdc. If the motor can operate from voltages of 60 Vdc or less, the +HV and VLOGIC can be driven from a single power supply.

P8 is also used for the connection point for a motor holding brake. These connect to pins 2 & 3 and are not shown here, because it is not part of the power and motor connections.

GROUNDING

PE GND is a Protective Earth Ground which is the zero-volt reference for voltages used in the drive and is also the connection point for fault currents that might flow from any failures in the drive that could expose a user to an electric shock. FGND, Frame Ground is referenced to the drive heatplate and has no connections to any circuits in the drive.

Internal connections from the heatplate to J4, J5, and J6 enable cabling for grounding and shielding. HVCOM, High-Voltage-Common is the 0V or 'ground' circuit for the high voltage circuits that drive the motor. SGND, Signal Ground is the 0V circuit for low power control and interface circuits. It is connected to HVCOM internally so that all internal circuits have a common "0V" connection.

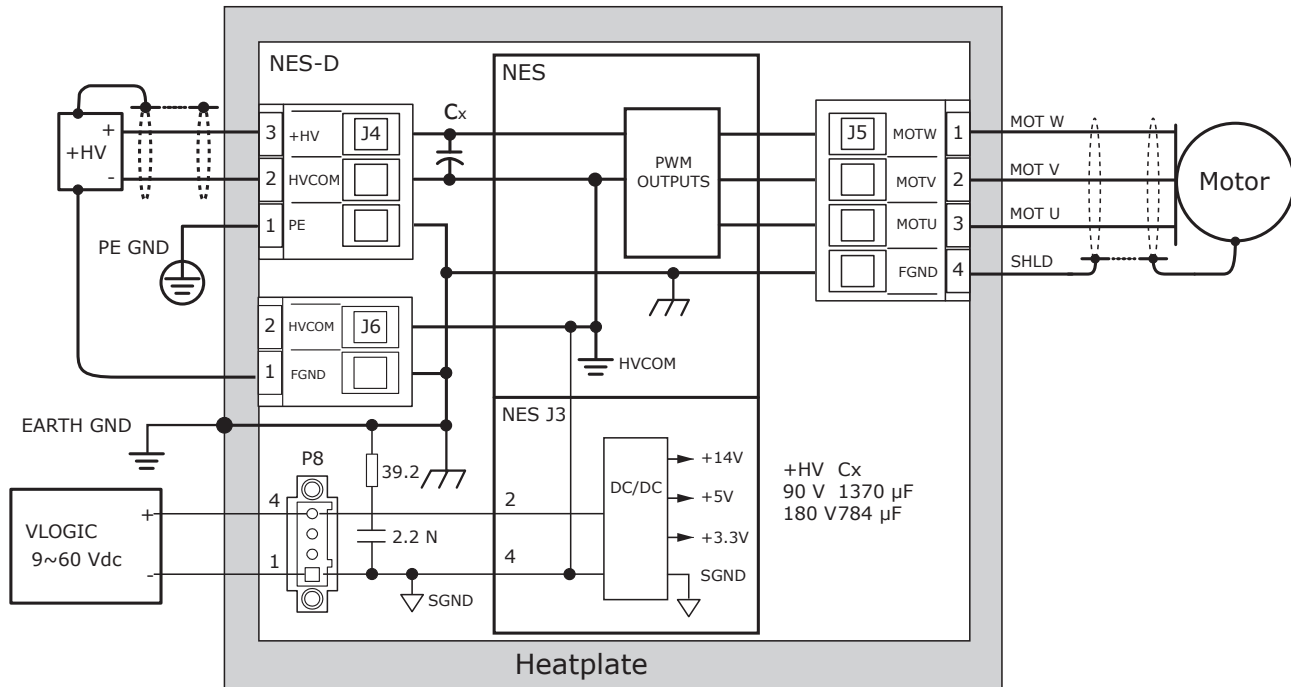

J4 +HV

Pin	Signal
3	+HV
2	HVCOM
1	FGND

J6 GROUNDS

Pin	Signal
2	HVCOM
1	FGND

P8 VLOGIC & BRAKE

Pin	Signal
4	VLOGIC input
3	VLOGIC to brake
2	Brake
1	HVCOM

J5 MOTOR

Pin	Signal
1	MOTW
2	MOTV
3	MOTU
4	FGND



Refer to the AN136 Accelnet External Regen Application Note, Part Number 16-125661.

VLOGIC +9~60. 24V power is recommended. 24V required if using 24V BRAKE.
If common to +HV do not exceed 60V, use REGEN protection, and diode isolation from HV.

NES-D VLOGIC & BRAKE

The brake circuit on the NES-D is a MOSFET driven by the brake output OUT4 of the NES.

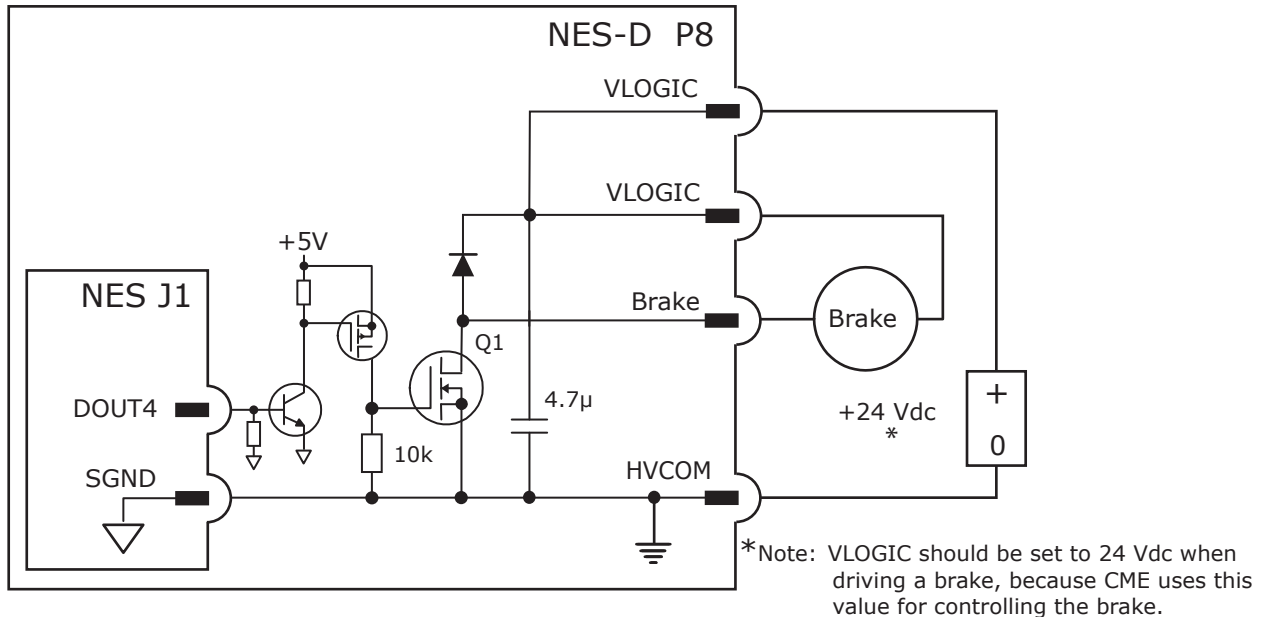

Specifications

Output	Data	Notes
Voltage Range	Max	+30 Vdc
Output Current	Ids	1.0 Adc

P8 BRAKE

Signal	Pins
Input VLOGIC	4
Brake VLOGIC	3
Brake	2
HVCOM	1

HI/LO Definitions: Outputs

Input	State	Condition
BRAKE [OUT4]	LO	Output MOSFET Q1 is OFF. Brake is un-powered and locks motor. Motor cannot move. Brake state is Active.
	HI	Output MOSFET Q1 is ON. Brake is powered, releasing motor. Motor is free to move. Brake state is NOT-Active.

CME Default Setting for Brake Output [OUT4] is "Brake - Active Low."

Active = Brake is holding motor shaft (i.e. the *Brake is Active*).
 Motor cannot move.
 No current flows in coil of brake.
 CME I/O Line States shows [OUT4] as LO.
 BRK Output voltage is HI (24V), MOSFET Q1 is OFF.
 Servo drive output current is zero.
 Servo drive is disabled, PWM outputs are OFF.

Inactive = Brake is not holding motor shaft (i.e. the *Brake is NOT-Active*).
 Motor can move.
 Current flows in coil of brake.
 CME I/O Line States shows [OUT4] as HI.
 BRK output voltage is LO (~0V), MOSFET Q1 is ON.
 Servo drive is enabled, PWM outputs are on.
 Servo drive output current is flowing.

NES-D INPUTS & OUTPUTS

Note: The following list the signal descriptions.
 • IN1~3 on the NES-D are 24V compatible.
 • IN4~5 are 12V tolerant.

P13 LOGIC INPUTS

Signal	Pins
IN1_24VTOL [IN1]	4
IN2_24VTOL [IN2]	5
IN3_24VTOL [IN3]	6
IN4	7
IN5	10
SGND	15,19

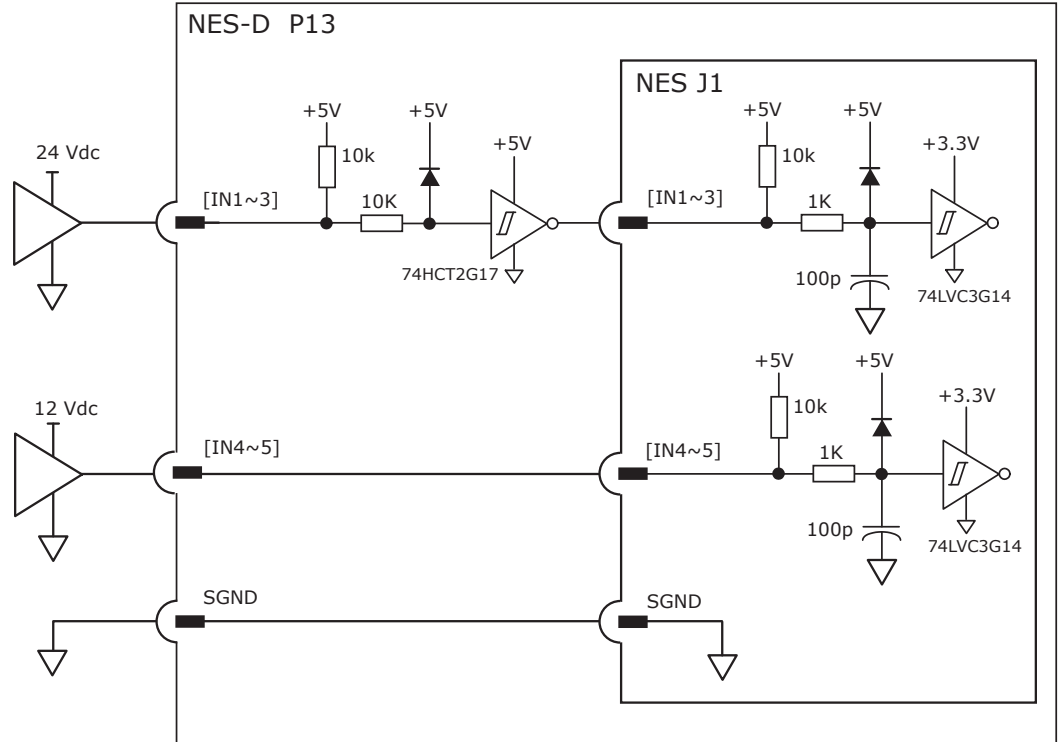

P13 LOGIC OUTPUTS

Signal	Pins
DOUT1 [OUT1]	16
DOUT2 [OUT2]	17
DOUT3 [OUT3]	18
SGND	15,19

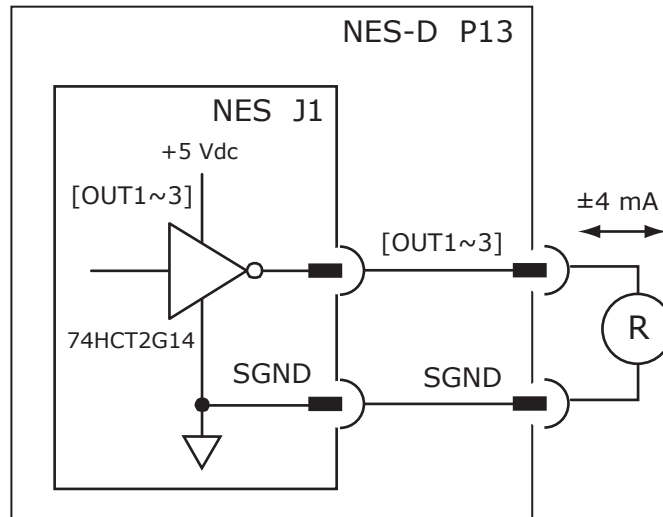

NES-D PRIMARY FEEDBACK ENCODER

P7 ENC1 INPUTS

Signal	Pins
ENCA1_UBC_DAT [A]	14
/ENCA1_UBC_DAT [/A]	13
ENCB1 [B]	12
/ENCB1 [/B]	11
ENCX1_UBC_CLK [X]	8
/ENCX1_UBC_CLK [/X]	7
OVERTEMP_IN [IN6]	10
+5VENC	2,4
SGND	5,15
FGND	1

Note: In the above table, the term, ENC1, is the Motor encoder and should be used in single-encoder applications. In dual-encoder applications, it can be assigned as a Primary or a Secondary using CME.

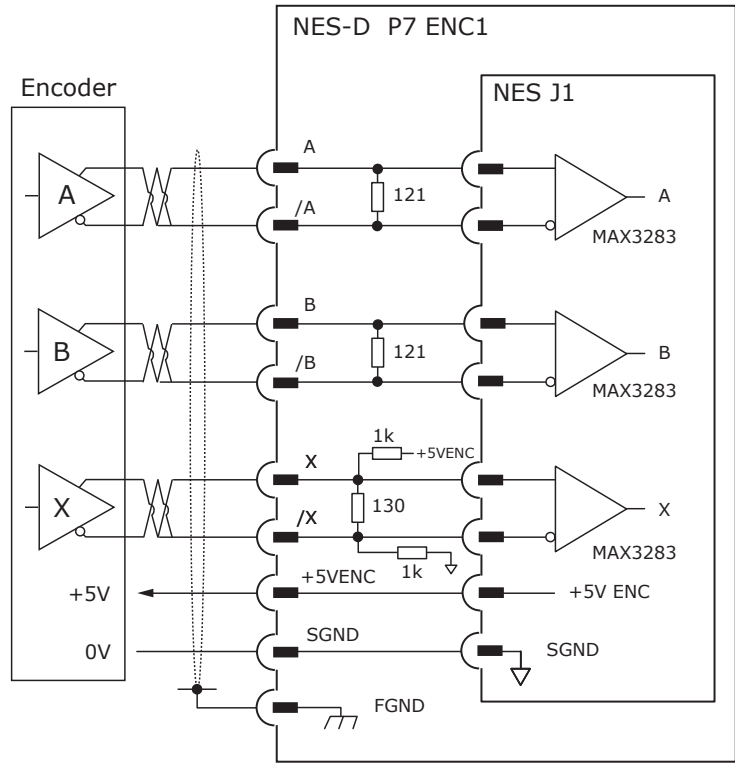

P7 HALL INPUTS

Signal	Pins
HALLU	3
HALLV	6
HALLW	9
SGND	5,15

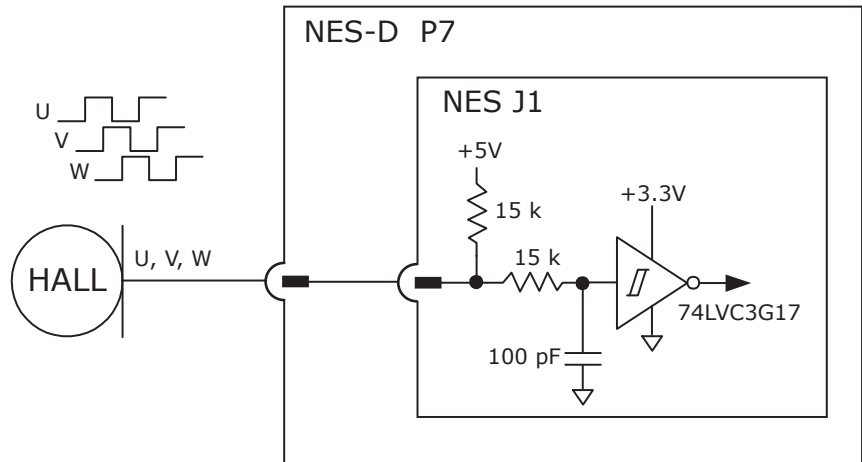

NES-D SECONDARY FEEDBACK ENCODER

P13 ENC2 INPUTS

Signal	Pins
ENCA2 [A]	26
/ENCA2 [/A]	25
ENCB2 [B]	24
/ENCB2 [/B]	23
ENCX2 [X]	22
/ENCX2 [/X]	21
IN5 [Fault]	10
+5VENC	20
SGND	15,19
FGND	1

Note: In the above table, the term, ENC2, is the Load encoder. Typically, it provides feedback from a load driven by the motor, and it is used in dual-encoder applications. In dual-encoder applications, it can be assigned as Primary or Secondary using CME.

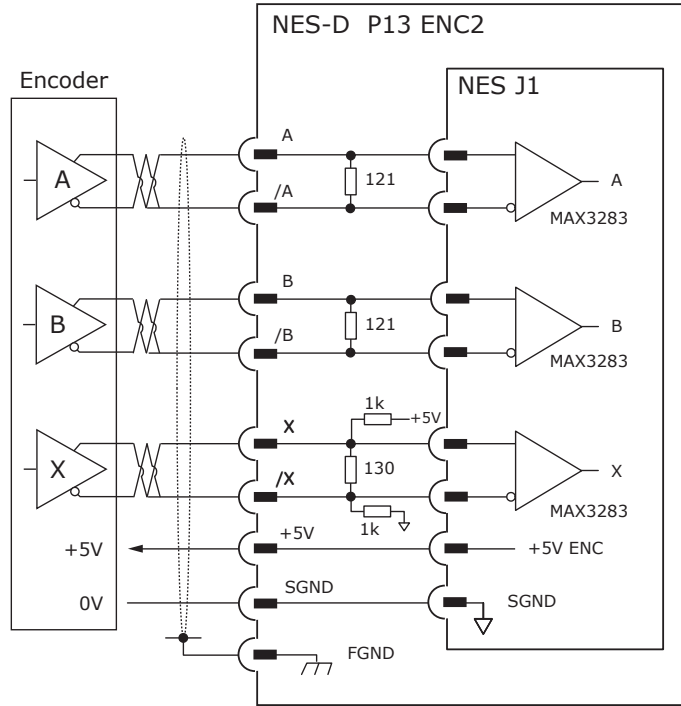

NES-D ANALOG INPUT: AIN1

As a reference input, it takes Position/Velocity/Torque commands from a controller. If it is not used as a command input, it can be used as a general-purpose analog input.

SPECIFICATIONS

Specifications	Data	Notes
Input Voltage	Vref	±10 Vdc
Input Resistance	Rin	5 kΩ

P13 ENC2 INPUTS

Signal	P13 Pins
REFIN1+ [Ref(+)]	3
REFIN1- [Ref(-)]	2
SGND	15,19

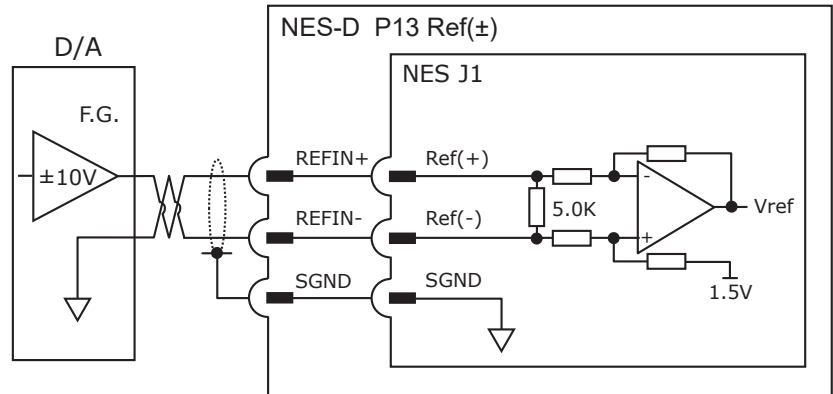

NES-D DIMENSIONS

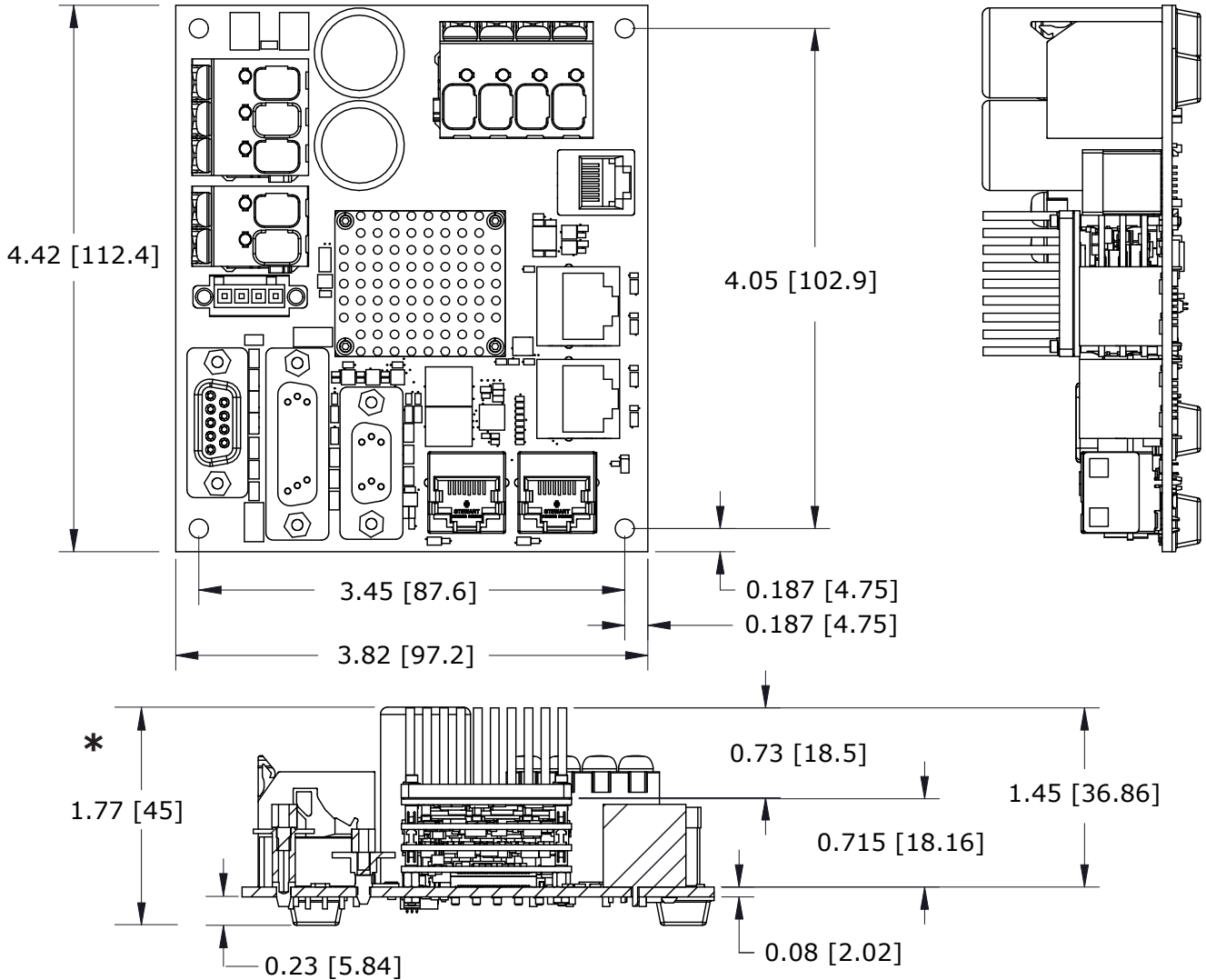

*Note: In the above diagram, the asterisk indicates the NES-D height is the same with or without the heatsink.

NES-D Dimensions

NES-D HEATSINK MOUNTING

A thermal pad is used in place of heatsink grease. The pad is die-cut to shape and has holes for the heat sink mounting screws. There are two protective sheets, blue on one side and clear on the other side. Remove both sheets when the interface pad is installed.

1. Remove the blue protective sheet from one side of the pad.
2. Place the interface pad on the drive, be sure to center the pad holes over the heatplate mounting holes.
3. Remove the clear protective sheet from the pad.
4. Mount the heatsink onto the drive. Make sure the holes in the heatsink, interface pad, and drive are aligned.
5. Torque the #0-80 mounting screws to 1 in-lb, 16 in-oz, 0.113 Nm.

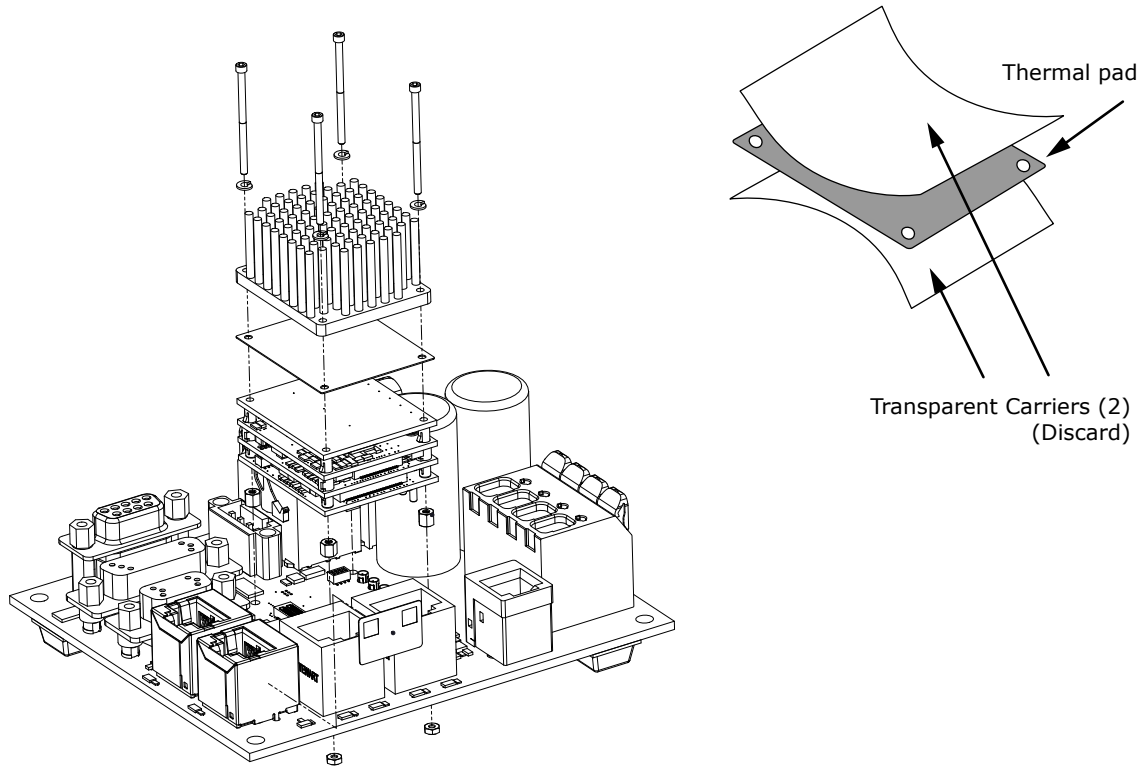

NES-D Heatsink Mounting Diagram

N-HK Heatsink Kit

Item	Description	Quantity
1	Screw, #0-80, hex, socket cap screw, 1 in [25.4 mm], stainless steel	4
2	Heatsink, 0.728 [18.49] tall, pins	1
3	Thermal pad, NES	1
4	Spacer, hex, 0.125 in [3.18 mm], 0-80 UNC 2B thread, 0.120 in [3.05 mm] tall, AL	4
5	Washer, medium split lock, #0, 18-8, stainless steel	4
6	Nut, #0-80, fine thread, stainless steel	4
7	IFixit Opening Tool	1

Note: The NES-090-70-D and NES-180-30-D are shipped from the factory with the Heatsink included.

NES-Z BOARD

The tables and NES-Z Signals and Pins diagram identify the jumpers, signals and pins on the NES-Z board.

Models
NES-090-70-Z
NES-180-30-Z
NES-180-10-Z
NES-090-10-Z

J9 ECAT

IN	Pin
RX1+	1
RX1-	2
TX1+	3
TX1-	4

J10 ECAT

OUT	Pin
RX2+	1
RX2-	2
TX2+	3
TX2-	4

P17 SHIELD

Signal	Pin
SHLD	1

P16 SHIELD

Signal	Pin
SHLD	1

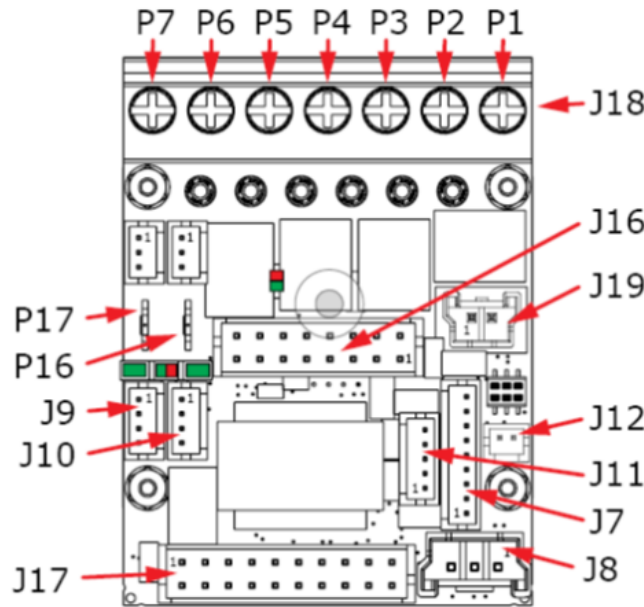

NES-Z Signals and Pins Diagram

J18

Pin	Signal
1	PE
2	HVCOM
3	+HV
4	MOTW
5	MOTV
6	MOTU
7	FGND

J19 VLOGIC

Signal	Pin
HVCOM	1
VLOGIC	2

J12 BRAKE

Signal	Pin
VLOGIC	2
BRAKE	1

J17 I/O

Signal	PIN	Signal
/ENCA2	2	REFIN1-
ENCA2	4	REFIN1+
IN1_24VTOL	6	/ENCX2
IN2_24VTOL	8	ENCX2
IN3_24V_TOL	10	+5VENC
DOUT1	12	SGND
DOUT2	14	/ENCB2
DOUT3	16	ENCB2
IN4	18	SGND
IN5	20	FGND

J16 STO

Signal	PIN	Signal
STO1_24V_IN	2	STO1_RTN
STO1_IN	4	STO1_RTN
N.C.	6	N.C.
STO2_24V_IN	8	STO2_RTN
STO2_IN	10	STO2_RTN
N.C.	12	N.C.
STO_STATUS_OUTPUT_RTN	14	SGND
+5V	16	STO_STATUS_OUTPUT

J11 HALLS

Signal	Pin
HALLU	5
HALLV	4
HALLW	3
+5VENC	2
SGND	1

J7 ENCODER 1

Signal	Pin
OVERTEMP_IN	9
ENCX1_UBC_CLK	8
/ENCX1_UBC_CLK	7
ENCB1	6
/ENCB1	5
ENCA1_UBC_DAT	4
/ENCA1_UBC_DAT	3
+5VENC	2
SGND	1

J8 RS-232

Signal	Pin
RX232TX1	3
RS232RX1	2
SGND	1

NES-Z: RS-232

RS-232 CONNECTION

The RS-232 port is used to configure the drive for stand-alone applications, or it is used for a configuration before it is installed into an EtherCAT network. CME software communicates with the drive over this link and it is then used for the complete drive setup. The EtherCAT Device ID is set via RS-232 along with other operating functions.

J8 RS-232

Signal	Pin
RX232TX1	3
RS232RX1	2
SGND	1

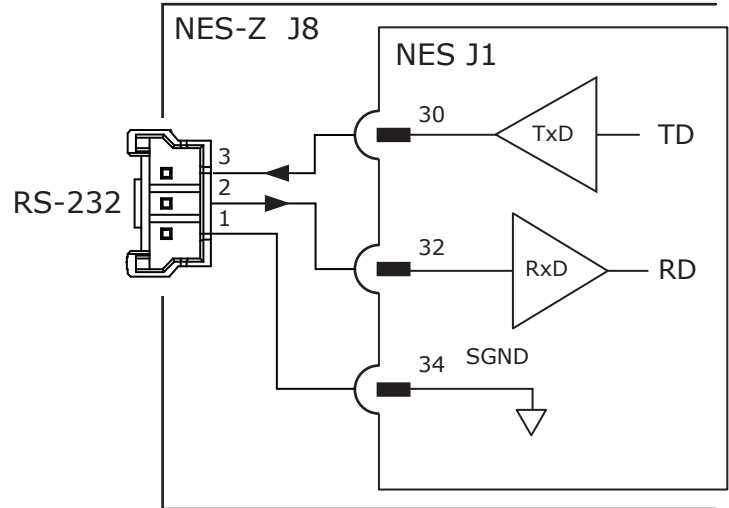

Compatibility with an existing serial adapter or cables can be done using an RJ-11 socket (6P6C) wired as shown in the diagram.

Molex: 42410-6170 Modular Jack, 6 terminals, size 6

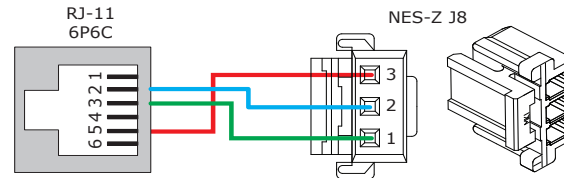

Copley will soon offer an SER-USB-M serial port adapter. This serial port is a full-duplex, three-wire (RxD, TxD, SGND) type that operates from 9,600 to 230,400. The SER-USB-M cable has output levels that are compatible with NPS-Z serial port.

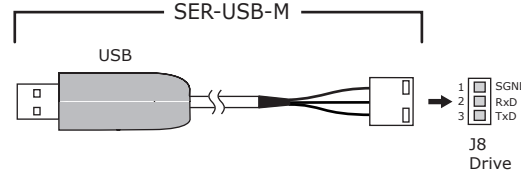

NES-Z: AMP STATUS LED

DRIVE STATUS LED (AMP)

A bi-color LED gives the state of the drive. Colors do not alternate, and can be solid ON or BLINKING. If multiple conditions occur, only the top-most condition will be displayed. When that condition is cleared, the next condition in the table will be shown.

LED	Condition Description
RED/BLINKING	Latching fault. Operation can not resume until the drive is Reset.
RED/SOLID	Transient fault condition. Drive can resume the operation when the condition causing the fault is removed.
GREEN/SLOW-BLINKING	Drive OK but NOT-enabled. Can run when enabled.
GREEN/FAST-BLINKING	Positive or Negative limit switch active. Drive can only move in the direction not inhibited by limit switch.
GREEN/SOLID	Drive OK and enabled. Can run in response to reference inputs or EtherCAT commands.

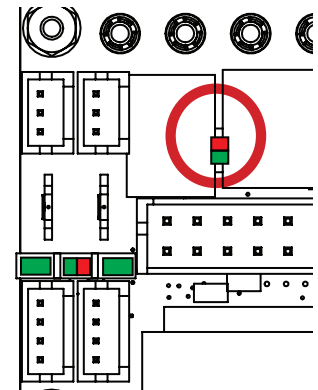

LATCHING FAULTS

Default	Optional (Programmable)
Short circuit (Internal or External)	Over-voltage
Drive over-temperature	Under-voltage
Motor over-temperature	Motor Phasing Error
Feedback Error	Command Input Lost
Following Error	Motor Wiring Disconnected
STO Active	Over Current (latched)

NES-Z: J9~J10 ETHERCAT COMMUNICATIONS

EtherCAT is the open, real-time Ethernet network developed by Beckhoff based on the widely used 100BASE-TX cabling system. EtherCAT enables high-speed control of multiple axes while maintaining tight synchronization of clocks in the nodes.

Data protocol is CANopen application protocol over EtherCAT (CoE) based on DSP-402 for motion control devices. More information on EtherCAT can be found on this web-site: <http://ethercat.org/default.htm>

ETHERCAT CONNECTIONS

J9 & J10 accept the Ethernet cables. The IN port connects to a master, or connects to the OUT port of a device that is 'upstream', between the Nano and the master.

The OUT port connects to 'downstream' nodes. If the drive is the last node on a network, only the IN port is used. No terminator is required on the OUT port.

ETHERCAT LEADS

RUN		ERR	
Green shows the state of the ESM (EtherCAT State Machine).		Red shows errors such as watchdog timeouts and an unsolicited state change in the drive due to local errors.	
LED	Condition	LED	Condition
OFF	= Init	OFF	= EtherCAT communications are working correctly
BLINKING	= Pre-operational	BLINKING	= Invalid Configuration, general configuration error
SINGLE FLASH	= Safe-Operational	SINGLE FLASH	= Local error, slave has changed EtherCAT state autonomously
ON	= Operational	DOUBLE FLASH	= PDO or EtherCAT watchdog timeout, or an application watchdog timeout has occurred.

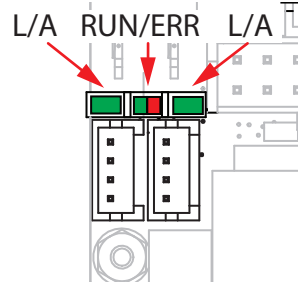

L/A

A green LED indicates the state of the EtherCAT network.

LED	Link	Activity	Condition
ON	Yes	No	= Port Open
FLICKERING	Yes	Yes	= Port Open with activity
OFF	No	(N/A)	= Port Closed

ETHERCAT DEVICE ID

In an EtherCAT network, slaves are automatically assigned fixed addresses based on their position on the bus. Stations on EtherCAT are automatically addressed by their bus location. The first drive on the network is station address -1. The second drive on the network is station address -2, and so on.

When a device must have a positive identification that is independent of cabling, a Device ID is required. This device can be set using digital inputs or set with a programmed value. Use the CME software to configure both of these modes.

ETHERCAT CONNECTORS

For user PC boards that use the standard RJ-45 receptacle for their network connections, the diagram below shows the connections to the EZ board connectors.

RJ-45

Signal	Pins
TX1+	1
TX1-	2
RX1+	3
N.C.	4
N.C.	5
RX1-	6
N.C.	7
N.C.	8

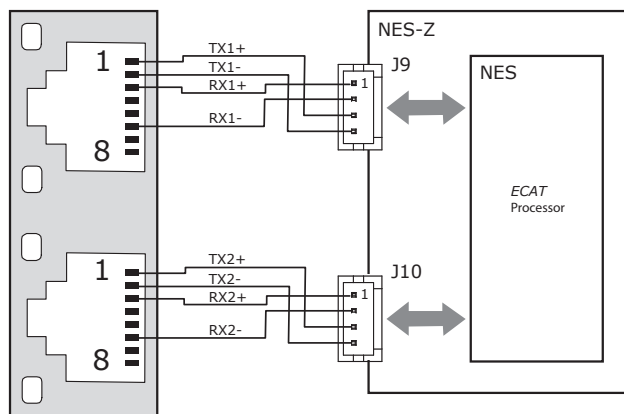

J9 ECAT-IN

Pin	Signal
1	RX1+
2	RX1-
3	TX1+
4	TX1-

J10 ECAT-OUT

Pin	Signal
1	RX2+
2	RX2-
3	TX2+
4	TX2-

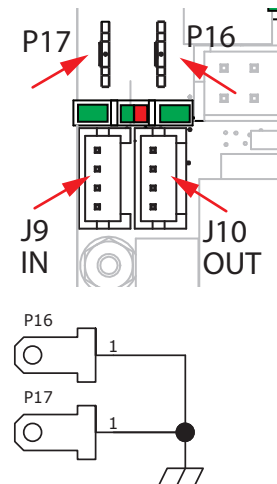

Note: In the above diagram, P16 & P17 are used for the shields in the J9 and J10 EtherCAT cables.

NES-Z: DRIVE AND NETWORK STATUS LEDS

The NES-Z status LEDs are listed below.

- The "STM" chip uses the serial data from ASYNC_TXD2 to drive LEDs.
- DR_STATUS_LED_X signals drive the AMP STATUS LED (refer to the detail on page 2).
- ECAT/CAN_XXX_LED show the network status of the drive communication.
- ECAT_LINKLEDx signals show the presence of activity on the ECAT connections.

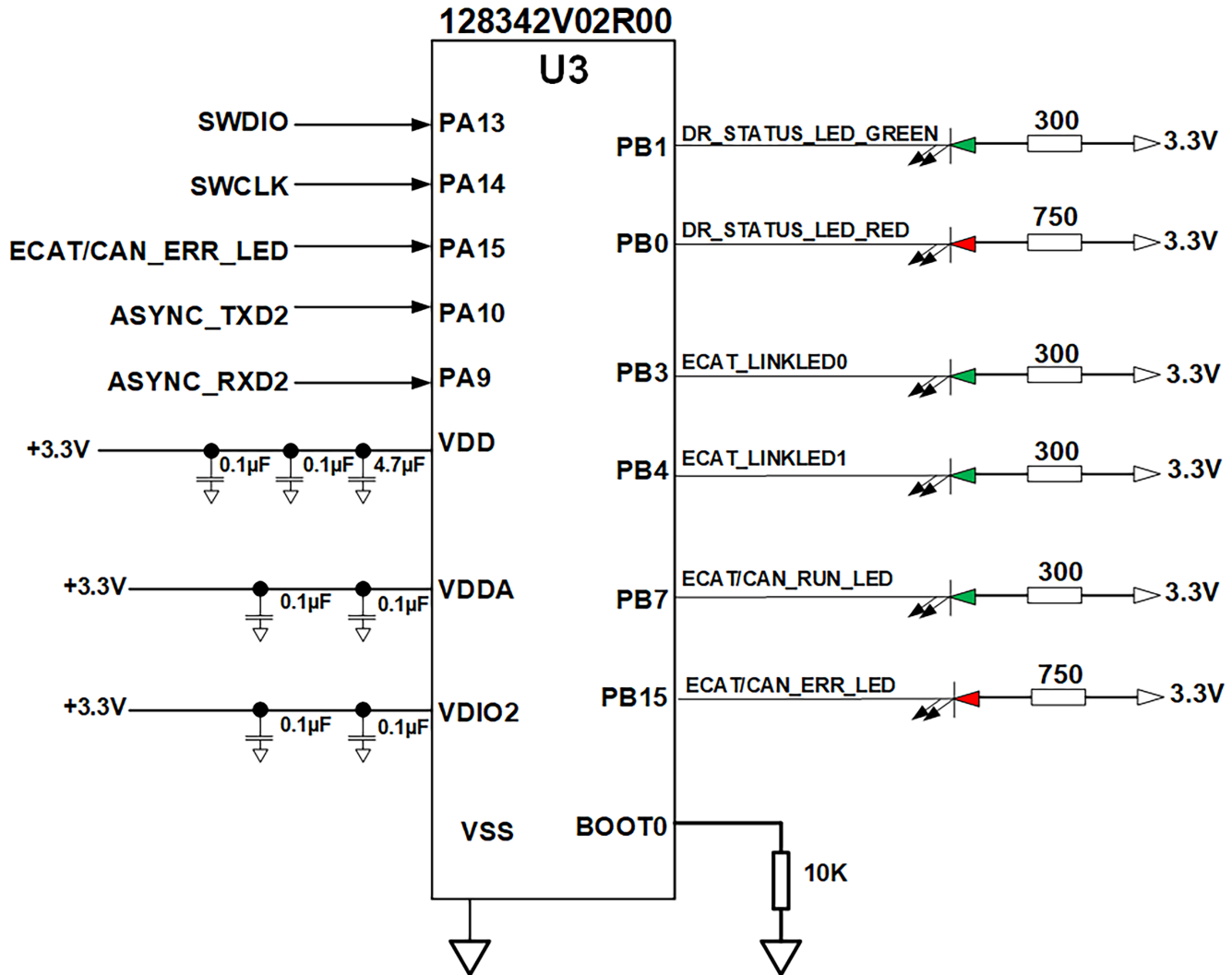

Drive and Network Status LEDS

NES-Z: J16 SAFE TORQUE OFF [STO]

DESCRIPTION

The following diagram shows the configuration to use the external 24V to energize the STO inputs. Both STO inputs must be energized in order to enable the drive.

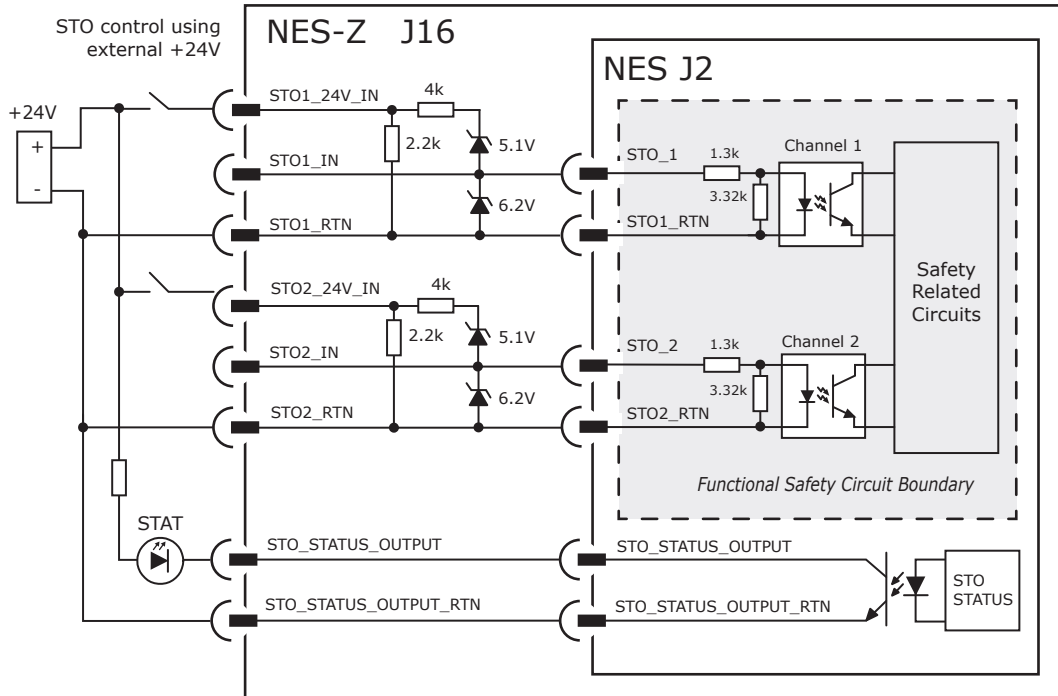

NES-Z J16 [STO]

Note: In the above diagram, the +24V can be driven from the VLOGIC power supply.

- The STOx_24V_IN circuits can tolerate the +60V limit of the VLOGIC input.
- The STOx_IN maximum voltage limits are +7.0 Vdc.

STO_STATUS_OUTPUT

STO1	0	1	0	1
STO2	0	0	1	1
STAT	0	0	0	1

Note: In the STO STATUS OUTPUT table, the following describes each row.

- STO1 & STO2 rows, 1=24V are applied between the IN-24V and RTN. 0=open-circuit.
- STAT row, 1=the optocoupler is ON, 0=the optocoupler is OFF.
- STAT output is ON (True) when both STO1 & STO2 are energized, allowing the drive to be enabled and to produce torque.

J16 STO

Signal	Pin	Signal
STO1_RTN	1	2
STO1_RTN	3	4
N.C.	5	6
STO2_RTN	7	8
STO2_RTN	9	10
N.C.	11	12
SGND	13	14
STO_STATUS_OUTPUT	15	16

STO OPERATION

STO Input Voltage	STO State
STO1_24V_IN AND STO2-IN-24V ≥ 16 Vdc	STO Inactive. Drive can be enabled to produce torque.
STO1_IN AND STO2_IN ≥ 3.0 Vdc	
STO1-IN-24V OR STO2-IN-24V < 16 Vdc	STO Active. Drive cannot be enabled to produce torque.
STO1_IN OR STO2_IN ≤ 2.0 Vdc	
STO1-IN OR STO2-IN Open	

Note: In the above table, the voltages are referenced between an STOx-IN and an STOx-RTN in J16.
E.g. V(STO1-IN) = V(STO1-24V-IN1) - V(STO1-RTN)

NES-Z: J16 SAFE TORQUE OFF (STO) BYPASS

Bypassing is used for users who do not use the STO function. The NS-Z-STO has jumpers that use the VLOGIC to energize the STO inputs. This disables the STO function, allowing the drive to be enabled from hardware inputs or a network. The graphic shows the wiring of the NS-Z-STO.

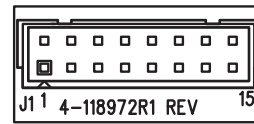
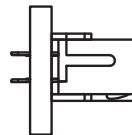
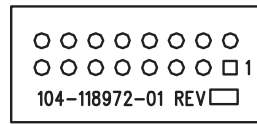
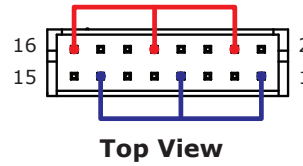

NES-Z: J18 +HV & MOTOR CONNECTIONS

J18 +HV: P2, P3

The +HV power supply connects to J18 pins P2 and P3. In the following diagram, the shield shown is optional and is primarily used for the reduction of the RF emissions coming from the drive. As shown, it connects to the case of the power supply. Note that the minus terminal is not grounded externally. This is because currents in the cables produce voltage drops. Grounding the supply at the drive ensures that such voltage drops do not appear in the drive circuits.

J18 MOTOR: P4~P7

Pins P4~P6 are used for the motor windings. Pin P7 is used for the cable shield. It connects to FGND on one end and should connect to the motor frame on the other end. This connection provides a return path for currents produced by the PWM outputs and the capacitance between the cable conductors, motor windings, and motor frame. While the frame is commonly grounded by mounting to equipment, without the shield connections, the PWM shield current could flow into external devices.

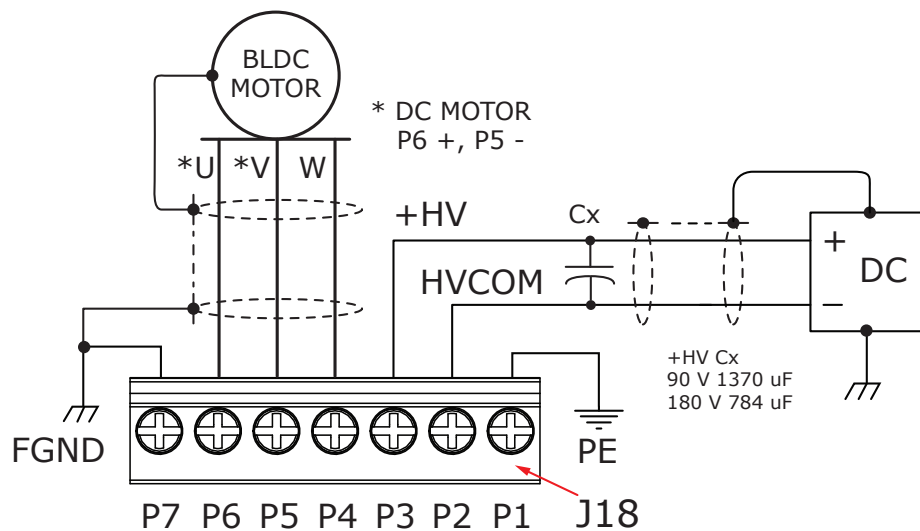

J18

Pin	Signal
P1	PE
P2	HVCOM
P3	+HV
P4	MOTW
P5	MOTV
P6	MOTU
P7	FGND

*Note: In the diagram, the asterisk indicates the DC brush motors connect to P6 & P5.

Motor Connections

Refer to the AN136 Accelnet External Regen Application Note, Part Number 16-125661.

VLOGIC +9~60. 24V power is recommended. 24V required if using 24V BRAKE.
If common to HV do not exceed 60V, use REGEN protection, and diode isolation from HV.

NES-Z: J12 BRAKE

J12 BRAKE:

The EZ board has components that can actuate a brake when controlled by DOUT4. If it is not used for the brake, DOUT4 is programmable for other functions. Use the CME software to set the custom brake configuration. This configuration includes settings for V Logic, Initial Voltage, Time at Initial Voltage, Holding Voltage, and PWM Period.

HI/LO Definitions: Outputs

Input	State	Condition
BRAKE [DOUT4]	LO	Output MOSFET Q1 is OFF. Brake is un-powered and locks motor. Motor cannot move. Brake state is Active.
	HI	Output MOSFET Q1 is ON. Brake is powered, releasing motor. Motor is free to move. Brake state is NOT-Active.

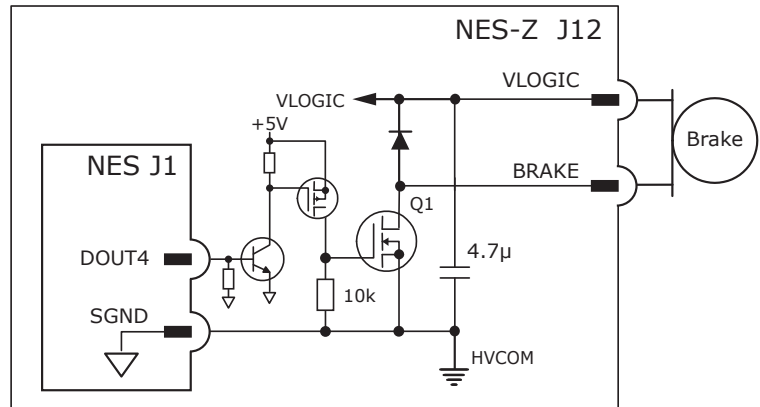

CME Default Setting for Brake Output [OUT4] is "Brake - Active Low."
 Active = Brake is holding motor shaft (i.e. the *Brake is Active*).
 Motor cannot move.
 No current flows in coil of brake.
 CME I/O Line States shows [OUT4] as LO.
 BRK Output voltage is HI (24V), MOSFET Q1 is OFF.
 Servo drive output current is zero.
 Servo drive is disabled, PWM outputs are OFF.

Inactive = Brake is not holding motor shaft (i.e. the *Brake is NOT-Active*).
 Motor can move.
 Current flows in coil of brake.
 CME I/O Line States shows [OUT4] as HI.
 BRK output voltage is LO (~0V), MOSFET Q1 is ON.
 Servo drive is enabled, PWM outputs are ON.
 Servo drive output current is flowing.

J12 BRAKE

Pin	Signal
2	VLOGIC
1	BRAKE

Specifications

Input	Data	Notes
Voltage Range	Max	+6~60 Vdc
Output Current	Ids	1.0 Adc

NES-Z: J19 VLOGIC

J19 VLOGIC:

The J19 VLOGIC powers the internal logic and control circuits in the drive. When the STO feature is used, it must be produced by power supplies with the transformer isolation from the mains, PELV or SELV ratings, and produce a maximum output voltage of 60 Vdc. If the motor can operate from voltages of 60 Vdc or less, the +HV and VLOGIC can be driven from a single power supply.

Specifications

Input	Data	Notes
Voltage Range	Max	+6~60 Vdc
Input Power	Typ	4 W
	Max	8 W

Note: The typical input power is no load on encoder +5V.
 The maximum input power is with two encoders @ 250 mA each, and +5V at maximum.

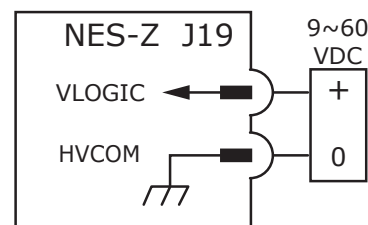

J19 VLOGIC

Pin	Signal
2	VLOGIC
1	HVCOM

 WARNING	<p>Refer to the AN136 Accelnet External Regen Application Note, Part Number 16-125661.</p>
	<p>VLOGIC +9~60. 24V power is recommended. 24V required if using 24V BRAKE. If common to +HV do not exceed 60V, use REGEN protection, and diode isolation from HV.</p>

NES-Z: J17 INPUTS & OUTPUTS

J17 has the following connections:

- Digital inputs 1~5
- Digital outputs 1~3
- Analog differential input *
- Secondary Quad A/B/X Encoder Input *
- * See page 39
- IN1~3 are 24V compatible.
- IN4~5 are 12V tolerant.

J17 LOGIC INPUTS

Signal	Pins
IN1_24VTOL	6
IN2_24VTOL	8
IN3_24VTOL	10
IN4	18
IN5	20
SGND	11,17

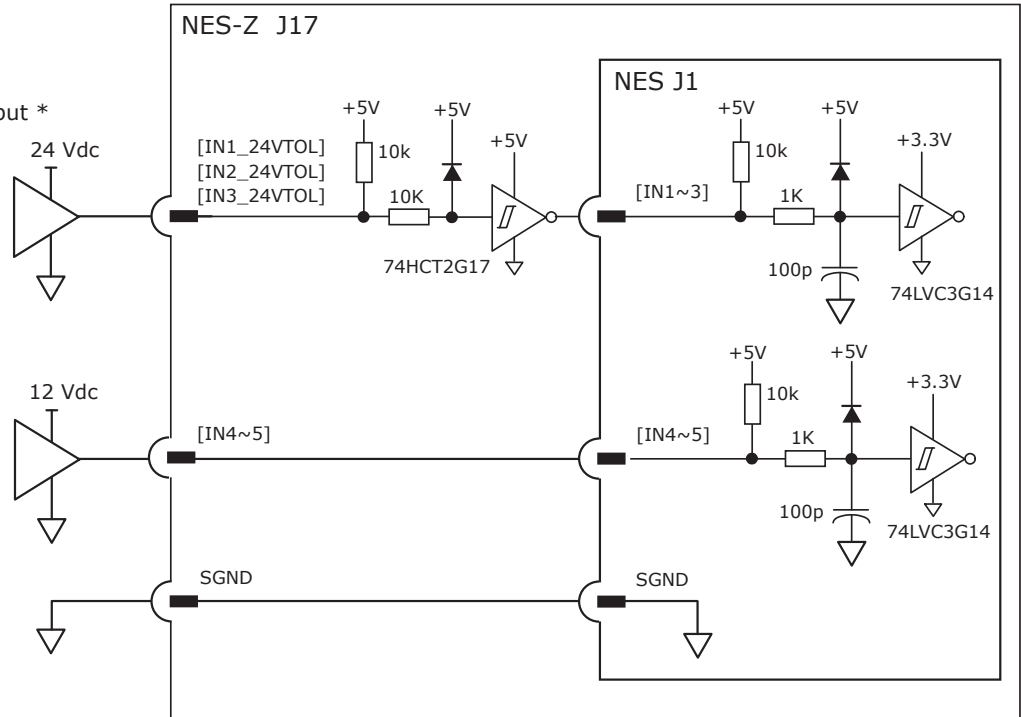

J17 LOGIC OUTPUTS

Signal	Pins
DOUT1 [OUT1]	12
DOUT2 [OUT2]	14
DOUT3 [OUT3]	16
SGND	11,17

J17 I/O

Signal	Pins	Signal
/ENCA2	2	1 REFIN-
ENCA2	4	3 REFIN+
IN1_24VTOL	6	5 /ENCX2
IN2_24VTOL	8	7 ENCX2
IN3_24VTOL	10	9 +5VENC
DOUT1	12	11 SGND
DOUT2	14	13 /ENCB2
DOUT3	16	15 ENCB2
IN4	18	17 SGND
IN5	20	19 FGND

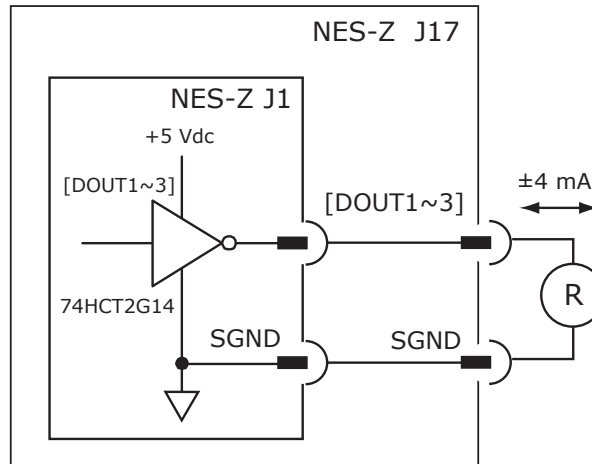

NES-Z: J17 ANALOG INPUT

As a reference input, it takes Position/Velocity/Torque commands from a controller. If it is not used as a command input, it can be used as general-purpose analog input.

SPECIFICATIONS

Specifications	Data	Notes
Input Voltage	Vref	±10 Vdc
Input Resistance	Rin	5.0 kΩ

Name	J17 Pins
Ref(+)	3
Ref(-)	1

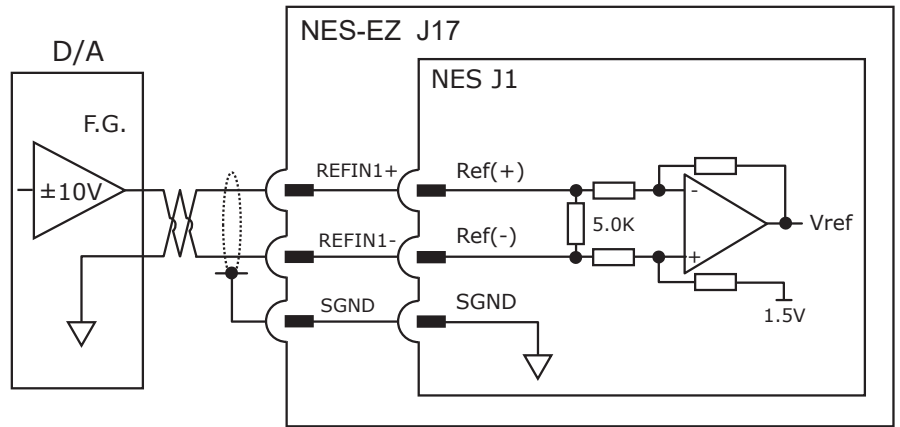

NES-Z: J17 SECONDARY ENCODER

The secondary encoder is used when the load is not connected directly to the motor.

J17 ENC2 INPUTS

Signal	Pins
ENCA2 [A]	4
/ENCA2 [/A]	2
ENCB2 [B]	15
/ENCB2 [/B]	13
ENCX2 [X]	7
/ENCX2 [/X]	5
+5VENC	9
SGND	11,17
FGND	19

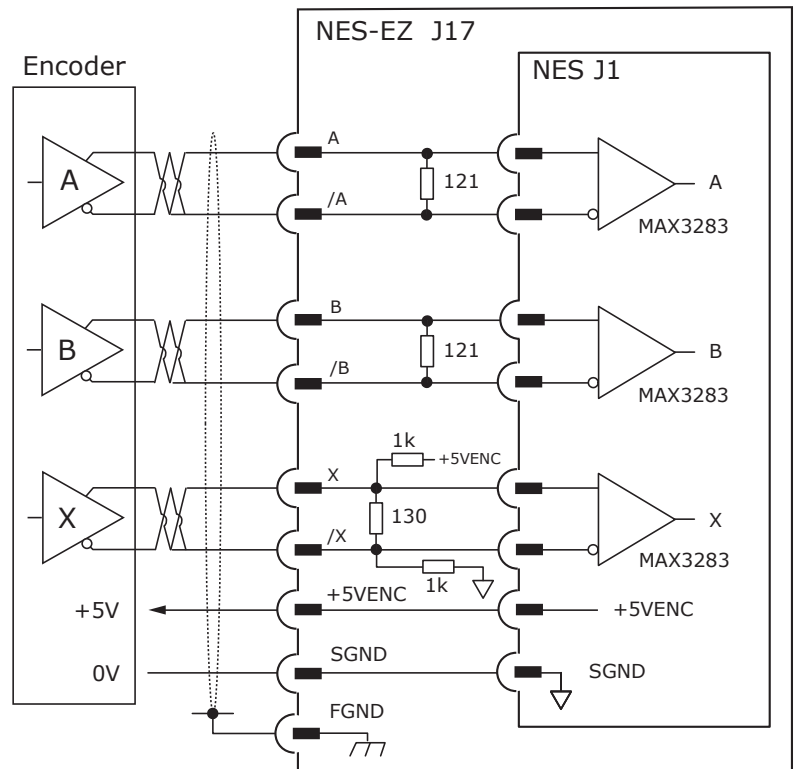

NES-Z: J7 PRIMARY ENCODER

The ENC1 is the Motor encoder and should be used in single-encoder applications. In dual-encoder applications, it can be assigned as Primary or Secondary using the CME.

J7 ENC1 INPUTS

Signal	Pins
ENCA1_UBC_DAT [A]	4
/ENCA1_UBC_DAT [/A]	3
ENCB1 [B]	6
/ENCB1 [/B]	5
ENCX1_UBC_CLK [X]	8
/ENCX1_UBC_CLK [/X]	7
OVERTEMP_IN [IN6]	9
+5VENC	2
SGND	1

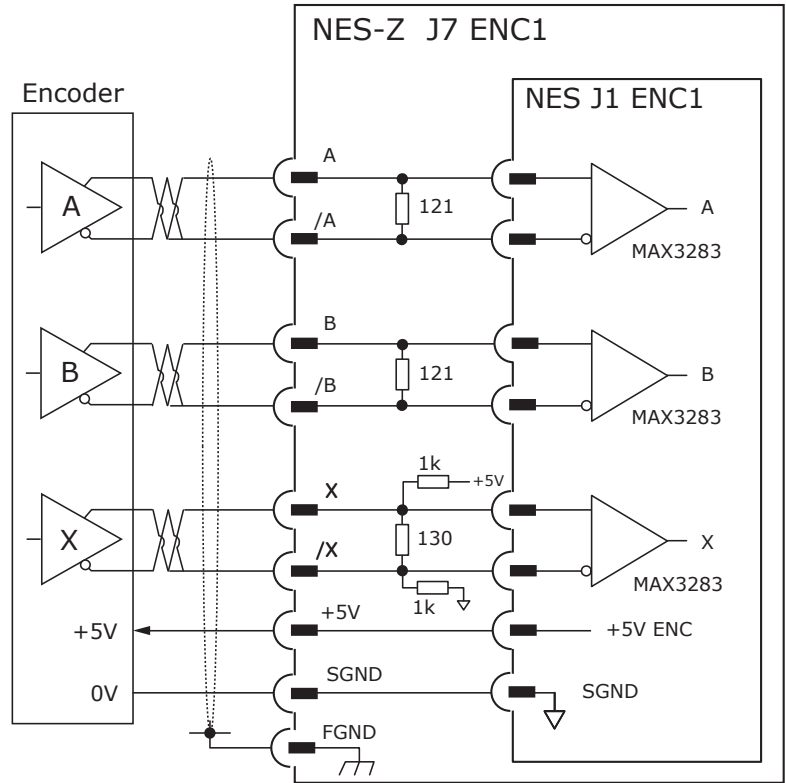

NES-Z: J7 OVERTEMP

The Input IN6 has a 49 microsecond rise time RC filter with a 4.99 kΩ pullup resistor to +5 VDC. Input IN6 is designed to interface with an industry standard PTC Thermistor IAW BS 49990111(1987) which is the standard for built-in thermal protection of the motor as a default. If it is not used for the Motemp function, the IN6 can be re-programmed for other input functions.

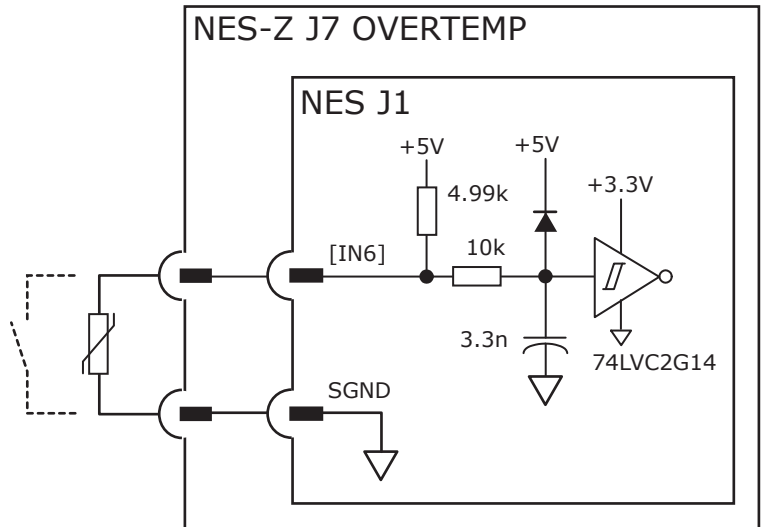

NES-Z: J11 HALLS

J11 HALL INPUTS

Signal	Pins
Hall U	5
Hall V	4
Hall W	3
+5VENC	2
SGND	1

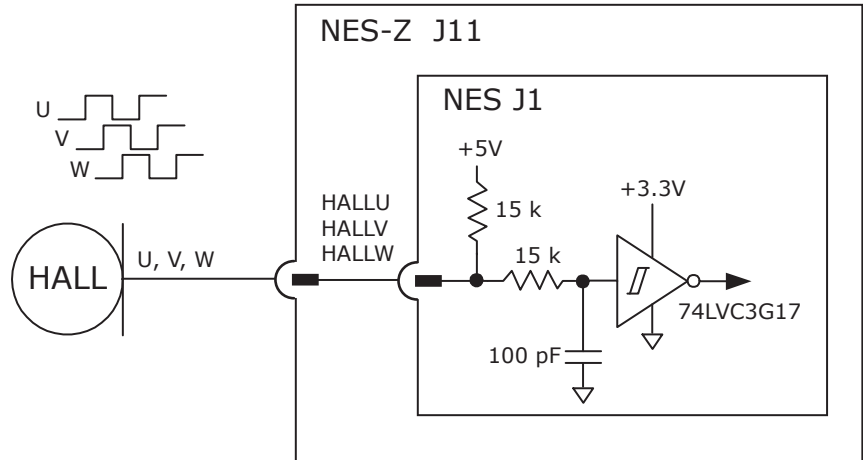

NES-Z: MECHANICALS

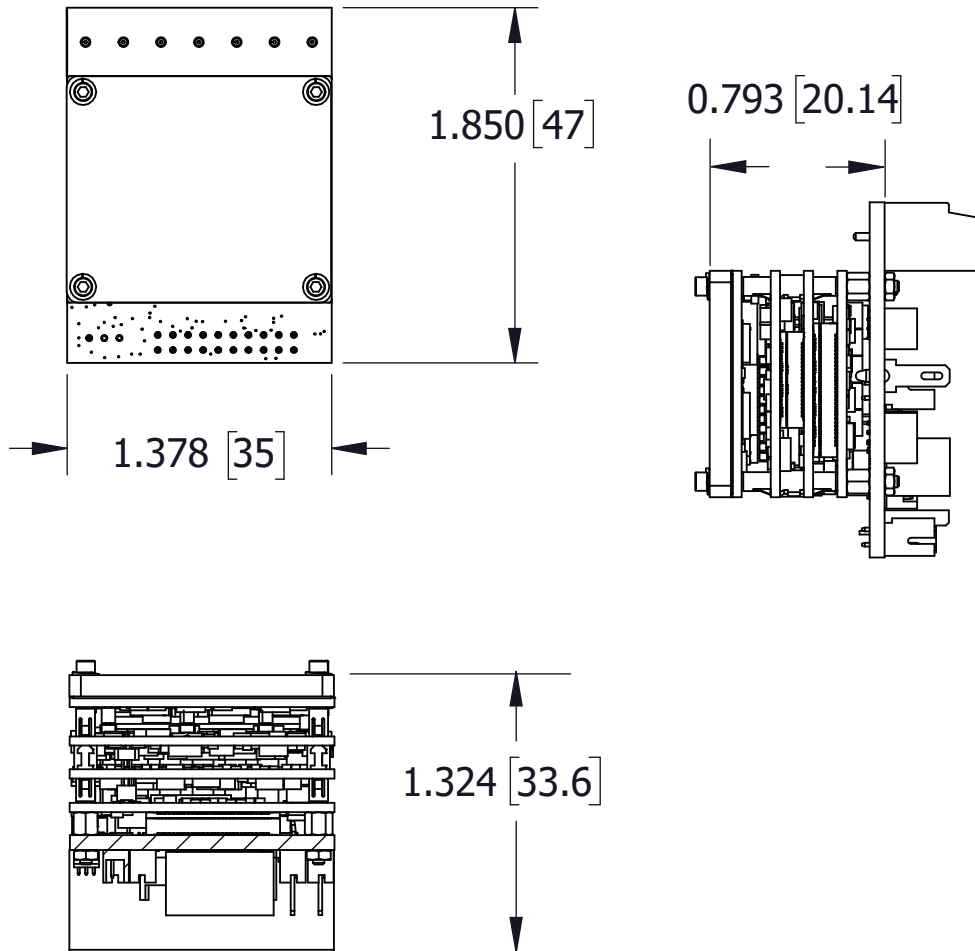

NES-Z Dimensions

NES-Z: MECHANICALS

In the NES-Z Components diagram, it shows the location of the parts in the drive when it is shipped. Use screw lengths of 1" [25.4 mm] to connect the nuts and washers and secure the parts together.

When the user secures the nuts to the underside of the board to mount the board to the panel, add the nuts' (depth or width) to this number to calculate the minimum length of screws required. For a panel with tapped holes, the 1" [25.4 mm] screw should be sufficient.

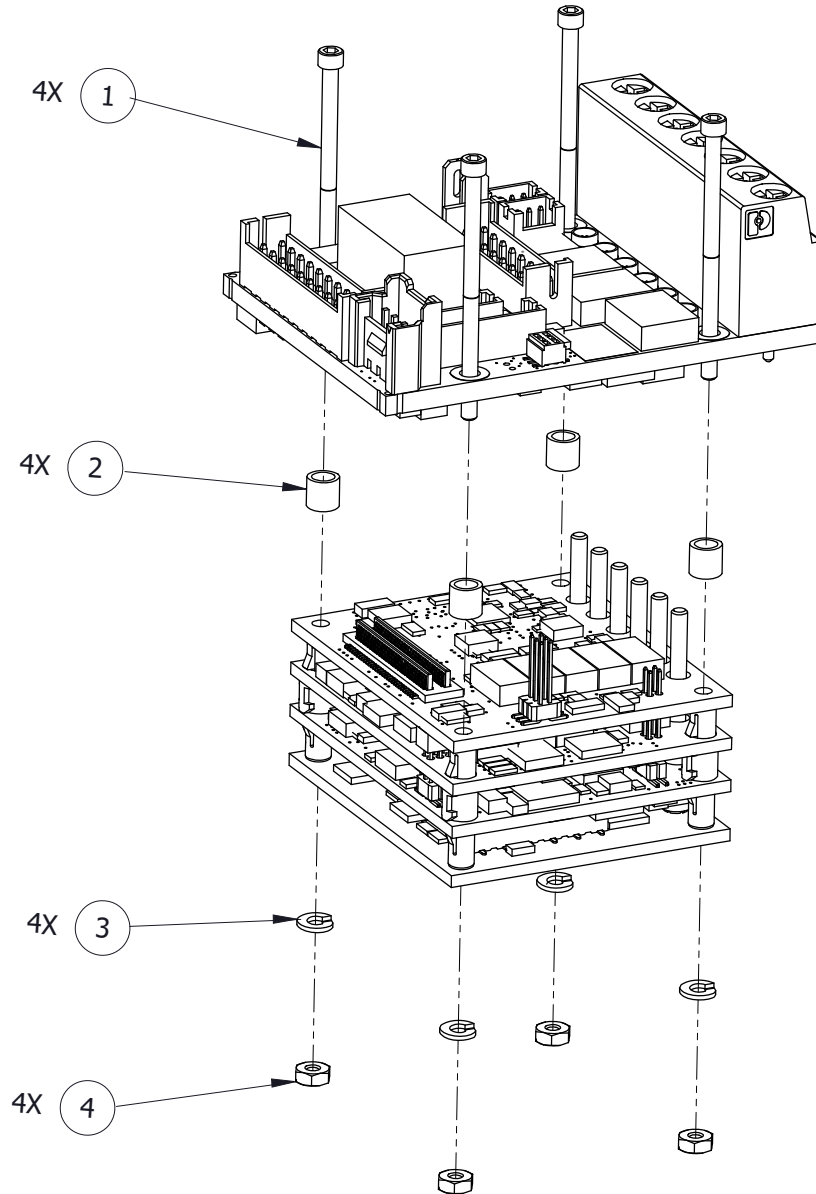

NES-Z Components Diagram

Item	Qty	Description	Mfgr, Part Number
1	4	Screw, 1", hex, 0-80, 18-8 THD, 80-1 SS	Fastenal: 0171020
2	4	Spacer, 3 mm, 0.090" I.D, 0.125" O.D.	Bivar: 937-3MM
3	4	Washer, split, 0.062 ID, 18-8, 0.137" O.D. SS	Fastenal: 017926
4	4	Nut, 0-80, 1/8", hex, socket, cap 18-8 SS	Fastenal: 0173909

ORDERING GUIDE

NANO

Part Number	Description
NES-090-10	Nano Micro Module EtherCAT NES servo drive, 5/10 A, 90 Vdc
NES-090-70	Nano Micro Module EtherCAT NES servo drive, 35/70 A, 90 Vdc
NES-180-10	Nano Micro Module EtherCAT NES servo drive, 5/10 A, 180 Vdc
NES-180-30	Nano Micro Module EtherCAT NES servo drive, 15/30 A, 180 Vdc
NES-090-10-D	Nano Micro Module EtherCAT NES with DEV board, not soldered, no heat sink
NES-090-70-D	Nano Micro Module EtherCAT NES with DEV board, soldered , with heat sink
NES-180-10-D	Nano Micro Module EtherCAT NES with DEV board, not soldered, no heat sink
NES-180-30-D	Nano Micro Module EtherCAT NES with DEV board, not soldered, with heat sink
NES-090-10-Z	Nano Micro Module EtherCAT NES with EZ board, not soldered, no heat sink
NES-090-70-Z	Nano Micro Module EtherCAT NES with EZ board, soldered , no heat sink
NES-180-10-Z	Nano Micro Module EtherCAT NES with EZ board, not soldered, no heat sink
NES-180-30-Z	Nano Micro Module EtherCAT NES with EZ board, not soldered, no heat sink

ACCESSORIES FOR NES

Part Number	Description
N-HK	Heatsink Kit

ACCESSORIES FOR NES-D

Part Number	Description
NS-D-CK	NES-D Connector Kit
STO-CK-04	NES-D Bypass Jumper
N-HK	Heatsink Kit
SER-USB-RJ11	USB to 6-pin Modular Adapter

CONNECTOR KIT FOR NES-D

Model	QTY	REF	Name	Description	MFGR Part Number
NS-D-CK Connector Kit	1	P8	VLOGIC and Brake	Connector, terminal-block, 4-pole, 3.5 mm	Wago: 734-104/107-000
	1			Tool, for P8	Wago: 734-231
	2	P7, P9	I/O	Connector Cover, D-Sub, 9-pin	3M: 3357-9209
	1	P9	Safety	Connector, D-Sub, 9-position, size 1	TE: 205204-4
	9	P9	Safety	Contact, pin, crimp, snap-in, 24~20 AWG	TE: 66506-9
	1	P13	I/O	Connector Cover, D-Sub, 15-pin	3M: 3357-9215
	1	P7	Feedback	Connector, D-Sub, 15-pin (HD), male, solder cup	Norcomp: 180-015-103L001
	1	P13	I/O	Connector, D-sub, 26-pin (HD), male, solder cup	Norcomp: 180-026-103L001

ORDERING GUIDE

ACCESSORIES FOR NANO MICRO MODULE NES-Z

Part Number	Description
NS-Z-CK	NES-Z Connector Kit
N-HK	Heat Sink Kit
SER-USB-M	USB to 3-Pin Molex adapter cable

CONNECTOR KIT FOR NES-Z

Models	Qty	Ref	Name	Description	MFR Part Number
NS-Z-CK Connector Kit	1	J12	Brake	CONN WIRE-MT HSG SKT 1X2P 1.25MM LKG NYL BEIGE	Hirose: DF13-2S-1.25C
	2	J13, J14	CAN	CONN WIRE-MT HSG SKT 1X3P 1.25MM LKG NYL BEIGE	Hirose: DF13-3S-1.25C
	2	J9, J10	EtherCAT	CONN WIRE-MT HSG SKT 1X4P 1.25MM LKG NYL BEIGE	Hirose: DF13-4S-1.25C
	1	J11	Halls	CONN WIRE-MT HSG SKT 1X5P 1.25MM LKG NYL BEIGE	Hirose: DF13-5S-1.25C
	1	J7	ENC1, Motemp	CONN WIRE-MT HSG SKT 1X9P 1.25MM LKG NYL BEIGE	Hirose: DF13-9S-1.25C
	24	J7, J9, - J10, J11, - J12, - J13, J14		CONN CONTC SKT CRMP 30-26GA 1MM MAX INSUL DIA AU	Hirose: DF13-2630SCFA
	1	J16	STO	CONN WIRE-MT HSG RCPT 2X8P 2X2MM LKG NYL BLK	Hirose: DF11-16DS-2C
	1	J17	IN1~5, DOUT1~3, ENC2, AREF	CONN WIRE-MT HSG RCPT 2X10P 2X2MM LKG NYL BLK MATING 129846	Hirose: DF11-20DS-2C
	36			CONN CONTC SKT CRMP 28-24GA 1.45MM MAX INSUL DIA AU	Hirose: DF11-2428SCFA(04)
	1	J19	Vlogic	CONN WIRE-MT HSG RCPT 1X2P 2MM LKG POLYEST NAT	Molex: 35507-0200
	1	J8	RS-232	CONN WIRE-MT HSG RCPT 1X3P 2MM LKG POLYEST NAT	Molex: 35507-0300
	2	P16, P17	Cable Shields	FASTON RCPT .11-.125W .02THK 26-22GA POSTIVE LOCK	TE: 353249-2
	3		DF13 Wires	CBL ASSY SKT CONTC TO SKT CONTC 1COND 26GA 7STRD BLK AU 12IN	Hirose: H4BBG-10112-B6
	19		DF13 Prewire	CBL ASSY SKT CONTC TO SKT CONTC 1COND 26GA 7STRD WHT AU 12IN	Hirose: H4BBG-10112-W6
	20		DR11 Wires	CBL ASSY SKT CONTC TO SKT CONTC 1COND 26GA 7STRD WHT AU 12IN	Hirose: H3BBG-10112-W6
	3		DF11 GP	CBL ASSY SKT CONTC TO SKT CONTC 1COND 26GA 7STRD RED AU 12IN	Hirose: H3BBG-10112-R6
	3		DF13 Wire	CBL ASSY SKT CONTC TO SKT CONTC 1COND 26GA 7STRD RED AU 12IN	Hirose: H4BBG-10112-R6
	1		P6, HVCOM	CBL ASSY SKT CONTC TO FREE END 1COND 24GA 7STRD BLK SN 12IN	Hirose: 0502128000-12-B4
	1		J19, +VLOGIC	CBL ASSY SKT CONTC TO FREE END 1COND 24GA 7STRD RED SN 12IN	Hirose: 0502128000-12-R4
	3		DF11	CBL ASSY SKT CONTC TO SKT CONTC 1COND 26GA 7STRD BLK AU 12IN	Hirose: H3BBG-10112-B6
1		Brake Wire	CBL ASSY SKT CONTC TO SKT CONTC 1COND 26GA 7STRD BLU AU 12IN	Hirose: H4BBG-10112-L6	
1	J16	STO Bypass PCB	BD ASSY, STO BYPASS BOARD	Copley: NS-Z-STO	

Note: Specifications subject to change without notice.

ORDERING GUIDE

16-121736 Document Revision History

Revision	Date	Remarks
00	October 11, 2019	Initial released version
01	November 12, 2019	NES-D info added
02	November 22, 2019	NES-090-10 added
03	December 6, 2019	Corrections to diagram on page 15.
04	March 20, 2020	Update module photo on page 1, update ordering guide
05	May 20, 2020	Added thermals
06	February 22, 2021	ECAT connections updated, NES-D only
AA	April 7, 2021	Pre-production revision - Changed revision to pre-production naming convention. Updated signal names to follow NES-D and added connector kit for NES-D.
AB	November 1, 2021	Pre-production revision - Changed revision to pre-production naming convention. Adding -Z board
07	June 22, 2022	Production revision Updated with 24V recommendations for VLOGIC, update with 3.3V input, update with capacitor on +HV input
08	August 8, 2022	Corrected pages 6 and 13 to match STO pinouts on page 14.
09	October 16, 2023	Updated text & graphics to change P1 to J1 (where applicable) and updated Accessories section. Added STO Warning on pages 6 & 14 and added U3 information on pages 24 & 35.